

REVISION			
REV.	DATE	DESCRIPTION	DRAWN BY

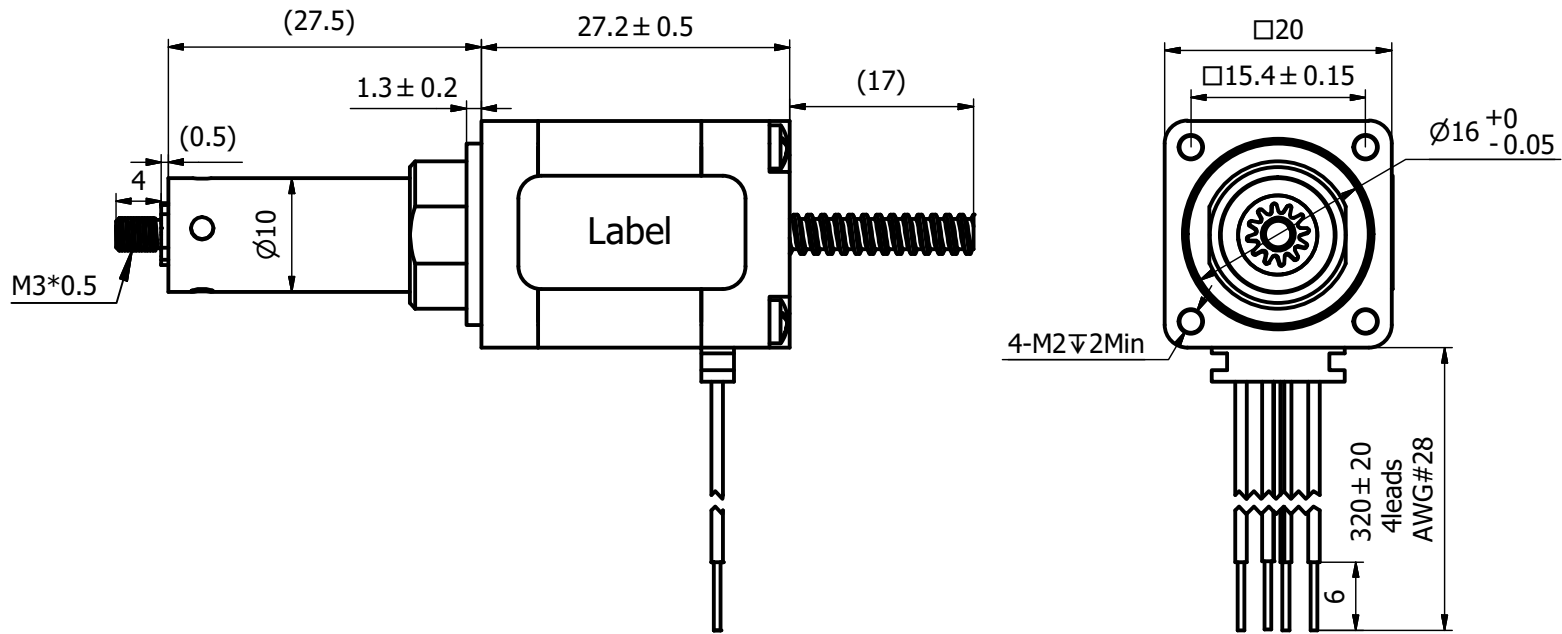

Notes,  
 1. To maximize output force and life of linear actuators,  
 radial load on lead screws should be avoided or be kept at a minimum.

<b>CUSTOMER</b>		NOTICE TO PERSONS RECEIVING THIS DRAWING THIS DRAWING IS ONLY CONDITIONALLY ISSUED, AND FOR THE SOLE PURPOSE OF INFORMING LICENSEES AND ASSOCIATE CONTRACTORS OF DINGS' MOTION, AND VENDORS THERE TO AND CUSTOMERS THEREOF, RECEIPT OR POSSESSION THEREOF DOES NOT CONFER TO TRANSFER ANY RIGHT IN THE SUBJECT MATTER OF THE DRAWING, THE DESIGN, CONSTRUCTION, TECHNICAL INFORMATION AND ALL OTHER SUBJECT MATTER SHOWN IN THIS DRAWING ARE AND REMAIN, EXCEPT AS MAY BE OTHERWISE INDICATED BY WRITTEN NOTICE HEREON, THE EXCLUSIVE PROPERTY OF SAID CORPORATION. THIS DRAWING MAY BE REPRODUCED ONLY BY LICENSEES AND ASSOCIATE CONTRACTORS OF SAID CORPORATION AND ONLY FOR LICENSED MANUFACTURE, AND BY VENDORS MANUFACTURING FOR SAID CORPORATION AND ONLY FOR LICENSEES AND ASSOCIATE CONTRACTORS.													
<b>WIRING CHART</b>		<b>EXCITATION SEQUENCE</b>		UNLESS OTHERWISE SPECIFIED ALL DIMENSIONS ARE IN MILLIMETERS AND TOLERANCES ARE AS BELOW PER ISO2768-ck.		DRAWN	Alice	DATE	2020/11/12	<b>DINGS</b>					
		CW	→			APPRVD		DATE							
		Red A+	+	-		MODEL		8K21-25.4		SIZE	A3	SHEET	1 OF 1		
		Red/wht A-	-	+						LINEAR	ANGULAR	SCALE	1: 1		REV
		Green B+			+					0~3	±0.2	0~10	±1.5°		
		Grn/wht B-			-					3~6	±0.5	10~50	±1°		
		CCW	←							6~30	±0.8	50~120	±30'		
					+	30~120	±1.5	120~400	±15'						