



VER 1.4 **Technical Manual**

**DS-CLS9-FCAO**



## Table of Contents

1. Features.....	4
2. Technical Parameters.....	4
3. Schematic and Interface Definition.....	5
3.1 CN1 (Power supply).....	5
3.2 CN2 (Motor).....	5
3.3 CN3 (Brake output) .....	5
3.4 CN4 (Encoder).....	5
3.5 CN5 (I/O).....	5
3.6 CN6 (IN) / CN7(OUT)(CANopen).....	6
3.7 SW1 (Setting switch).....	7
3.7.1 Mailing Address.....	7
3.7.2 Communication Baud Rate.....	8
3.7.3 Trial Operation.....	8
4. LED Indicator.....	9
4.1 Status Display.....	9
4.2 Site Number Display.....	9
4.3 Alarm Display.....	9
4.4 Overtravel Display.....	10
5. Power Supply.....	11
5.1 Voltage.....	11
5.2 Current.....	11
5.3 Regeneration of discharge.....	11
6. Motor Connection.....	12
7. Typical Signal Connection.....	13
7.1 Common Positive Connection.....	13
7.2 Common Cathode Connection of Output Signal.....	13
8. Wiring Requirements.....	14
9. Installation Dimensions (unit : mm).....	15
10. CANopen Communication.....	16
10.1 CANopen Communications Service.....	16
10.2 CANopen Communication Object Identifier.....	16
10.3 Object Dictionary (OD).....	17
10.3.1 Object Dictionary Overview.....	17
10.3.2 Object Type.....	18

10.3.3	Access Properties.....	18
10.3.4	Communication Object Dictionary.....	18
10.4	Network Management (NMT) .....	19
10.5	NMT Error Control.....	20
10.5.1	Node / Lifetime Protection.....	20
10.5.2	The Heartbeat.....	21
10.5.3	Communications State Machine.....	22
10.6	Service Data Object (SDO).....	23
10.7	Process Data Object (PDO) .....	24
10.7.1	Transmission Framework and Features of PDO.....	24
10.7.2	The PDO Object.....	26
10.7.3	Communication Parameters of PDO.....	27
10.7.4	PDO Mapping Parameters.....	29
10.8	Synchronization Object (SYNC) .....	30
10.8.1	Sync Generator.....	30
10.8.2	Transmission Framework for Synchronous Objects.....	30
10.9	Emergency Target Service (EMCY) .....	31
11.	Parameter Description and Setting.....	32
11.1	SDO Parameters List.....	32
11.1.1	Configuration Parameters.....	32
11.1.2	Motion Parameter.....	34
12.	Common Functions.....	35
12.1	Control Word and Operation Mode.....	35
12.2	Peak Output Current.....	39
13.	Appendix : Return to Origin Method.....	39

## 1. Features

- Input power : DC 24V ~ 48V
- Output rated current (peak value) : 6.5A
- Support CANopen communication protocol , Support control mode PP, PV, HM,PT

## 2. Technical Parameters

Drive model		DS-CLS9-FCAO
Adapted motor	Suitable for two-phase hybrid stepping motor, the maximum adaptation is 6.5A (peak)	
Power supply	DC 24V ~ 48V	
Output current	0.1A ~ 6.5A/phase (peak)	
Drive method	Full-bridge bipolar PWM drive	
Device initialization time	2s	
Input signal	2 high-speed input signal	Optocoupler input voltage : H = 3.5 - 26V , L = 0 - 0.8V On current 5~8mA
	5 universal input signals	Optocoupler input voltage : H = 24V , L = 0 - 0.8V On current 5~8mA
Output signal	3 common output signal	Photoelectric isolated output, withstand voltage up to 30VDC, maximum saturation current 50mA
Size	156×97×33.5 mm	
Weight	about 500g	
Use surroundings	Use occasion	Avoid dust, oil mist and corrosive gases
	Humidity	< 85 % RH, Non-condensing
	Temperature	0°C - +40°C
	Dissipate heat	Installation in a ventilated environment

### 3. Schematic and Interface Definition

#### 3.1 CN1 (Power supply)

Terminal number	Icon	Pin.	Signal name
CN1		2	V+ (DC24V ~ 48V)
		1	GND

#### 3.2 CN2 (Motor)

Terminal number	Icon	Pin.	Signal name
CN2		4	A+
		3	B+
		2	A-
		1	B-

#### 3.3 CN3 (Brake output)

Terminal number	Icon	Pin.	Signal name
CN3		2	BRK+
		1	BRK-

i

Notes

1. The maximum output current is 500mA, without external relay.

2. By default, this function is turned off at the factory. When you need this function, please turn it on and set the relevant parameters through the debugging software.

#### 3.4 CN4 (Encoder)

Pin.	Signal name	Pin.	Signal name
1	A+	2	A-
3	B+	4	B-
5	Z+	6	Z-
7	+5V	8	0V
9	FG	10	NC

Schematic diagram

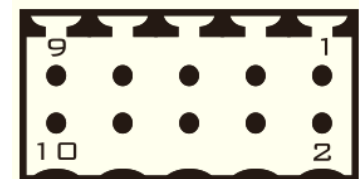

#### 3.5 CN5 (I/O)

Schematic diagram

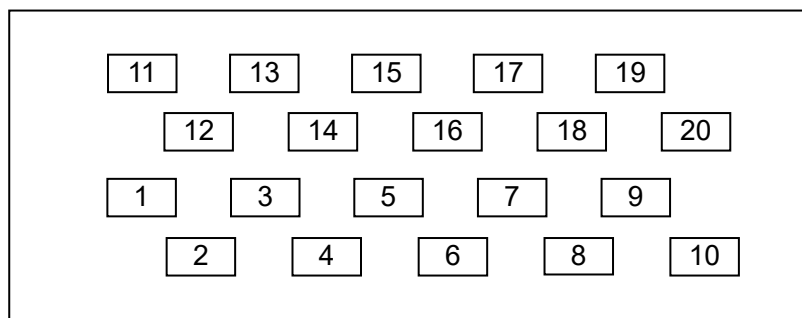

Terminal number	Pin	Signal name	description
CN5	1	COM ( IN )	Describe the common terminal of single-ended input signal, common anode or common cathode
	2	IN1	Single-ended input signal IN1 ~ IN5, 18 ~ 24V valid, maximum input frequency 10KHz, signal definition can be configured, IN1 defaults to positive limit, IN2 defaults to negative limit, IN3 defaults to origin, IN4 and IN5 defaults to general input
	3	IN2	
	4	IN3	
	5	IN4	
	6	IN5	
	7	IN6+	Differential input signal IN6, 5 ~ 24V is valid, the maximum input frequency is 500KHz, the signal definition can be configured, the default is the probe input signal 1
	8	IN6-	
	9	IN7+	Differential input signal IN7, 5 ~ 24V is valid, the maximum input frequency is 500KHz, the signal definition can be configured, the default is the probe input signal 2
	10	IN7-	
	11	OUT1	Single-ended output signal, common cathode connection, maximum output current 50mA, maximum withstand voltage 30Vdc. The output function can be configured, the default alarm output
	12	OUT2	Single-ended output signal, common cathode connection, maximum output current 50mA, maximum withstand voltage 30Vdc. The output function can be configured, the default alarm output
	13	OUT3	Single-ended output signal, common cathode connection, maximum output current 50mA, maximum withstand voltage 30Vdc. The output function can be configured, the default alarm output
	14	COM ( OUT )	Output common cathode common terminal
	15	Encoder A+	Manufacturer reserve
	16	Encoder A-	Manufacturer reserve
	17	Encoder B+	Manufacturer reserve
	18	Encoder B-	Manufacturer reserve
	19	Encoder Z+	Manufacturer reserve
	20	Encoder Z-	Manufacturer reserve

## .6 CN6 (IN) / CN7 (OUT) (CANopen)

Pin.	Signal name	Pin.	Signal name
1	CANH	2	CANL
3	Manufacturer reserve	4	GND
5	GND	6	Manufacturer reserve
7	Terminal resistance (CN7)	8	Terminal resistance (CN7)

Standard product: RJ45 type × 2

View each pin position from the insertion point of view

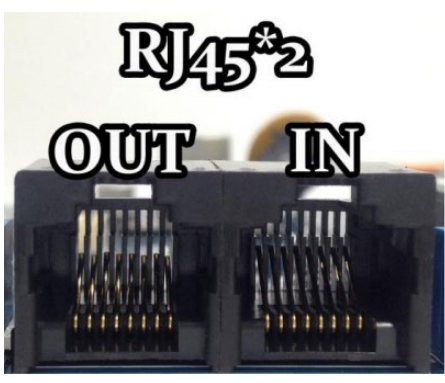

<b>i</b>	<b>Notes</b>	<ol style="list-style-type: none"> <li>When using multiple units connected in series, when the last CN7 pin 1 and 8 are short-circuited, and the 2-pin and 7-pin are short-circuited, it is the access terminal resistor.</li> <li>CN6 does not contain terminating resistors.</li> </ol>
----------	--------------	---

### 3.7 SW1 (Setting Switch)

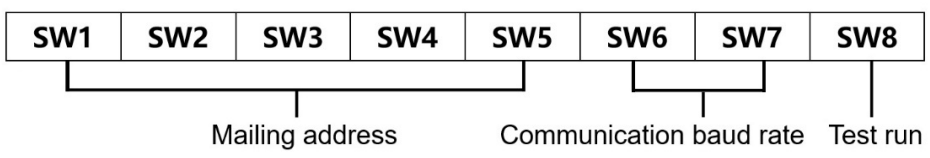

#### 3.7.1 Mailing Address

Using CAN bus, users can control up to 127 DS-CLS9-FCAO drives at the same time. The communication address setting of the drive adopts a 5-bit DIP switch.

The address setting range is 1-32, of which address 32 is reserved for the system. When the drive address is set greater than 31, it needs to use the upper debugging software to set and save it.

And the switch needs to be all set to OFF (default is 1).

<b>i</b>	<b>Notes</b>	<ol style="list-style-type: none"> <li>One controller can control up to 127 DS-CLS9-FCAO drives at the same time through the CAN bus.</li> <li>The communication address setting of each driver must be unique, otherwise it will cause communication errors.</li> </ol>
----------	--------------	--

DIP switch					Real address (DEC)	Show address (HEX)
SW1	SW2	SW3	SW4	SW5		
ON	ON	ON	ON	ON	1	01H
ON	ON	ON	ON	OFF	2	02H
ON	ON	ON	OFF	ON	3	03H
ON	ON	ON	OFF	OFF	4	04H
ON	ON	OFF	ON	ON	5	05H
ON	ON	OFF	ON	OFF	6	06H
ON	ON	OFF	OFF	ON	7	07H
ON	ON	OFF	OFF	OFF	8	08H

ON	OFF	ON	ON	ON	9	09H
ON	OFF	ON	ON	OFF	10	0AH
ON	OFF	ON	OFF	ON	11	0BH
ON	OFF	ON	OFF	OFF	12	0CH
ON	OFF	OFF	ON	ON	13	0DH
ON	OFF	OFF	ON	OFF	14	0EH
ON	OFF	OFF	OFF	ON	15	0FH
ON	OFF	OFF	OFF	OFF	16	10H
OFF	ON	ON	ON	ON	17	11H
OFF	ON	ON	ON	OFF	18	12H
OFF	ON	ON	OFF	ON	19	13H
OFF	ON	ON	OFF	OFF	20	14H
OFF	ON	OFF	ON	ON	21	15H
OFF	ON	OFF	ON	OFF	22	16H
OFF	ON	OFF	OFF	ON	23	17H
OFF	ON	OFF	OFF	OFF	24	18H
OFF	OFF	ON	ON	ON	25	19H
OFF	OFF	ON	ON	OFF	26	1AH
OFF	OFF	ON	OFF	ON	27	1BH
OFF	OFF	ON	OFF	OFF	28	1C H
OFF	OFF	OFF	ON	ON	29	1D H
OFF	OFF	OFF	ON	OFF	30	1E H
OFF	OFF	OFF	OFF	ON	31	1F H
OFF	OFF	OFF	OFF	OFF	customize	customize

### 3.7.2 Communication Baud Rate

DIP switch		baud rate (bps)
SW6	SW7	
ON	ON	125K
ON	OFF	250K
OFF	ON	500K
OFF	OFF	1M

### 3.7.3 Trial Operation

The test run function is used to verify the performance of the drive. Turn the SW8 switch to ON when the power is off. Then turn on the power and in the state of no pulse input, turn the SW8 gear switch from the ON gear to the OFF gear, and then switch from the OFF gear to the ON gear after 1 second, that is, start the trial running function (the motor rotates at 1 rpm). Circular forward and reverse motion at the speed of one circle).



## 4. LED Indicator

### 4.1 Status Display

display	Description
	Motor rotation display Lights when the motor rotates, lights off when stopped
	Device enable status The device enable indicator is on and the device disable indicator is off.
	Displayed in command input Command input light is on
	Displayed in CONNECT CONNECT light is on

### 4.2 Site Number Display

The site number is displayed verbatim and ends with H. After the CONNECT connection is successful, only the status is displayed.

Example : Site number : 45H

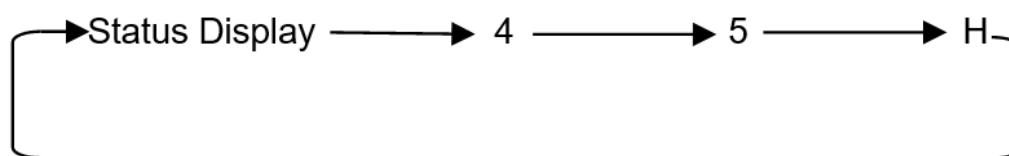

### 4.3 Alarm Display

The alarm code is displayed verbatim and flashes, ending with E

Example : Alarm code E8

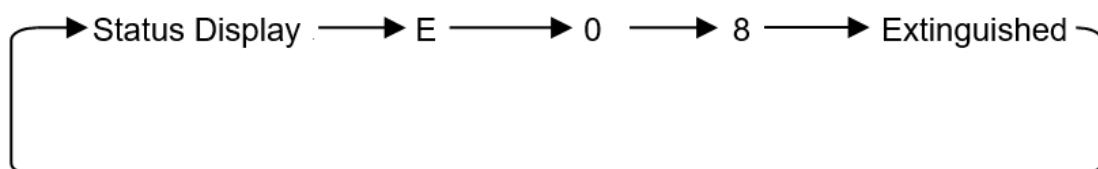

Features	Alarm code	Alarm /warning	Description
Motor overcurrent	alarm	AH	Motor phase current overcurrent or drive failure
Motor phase loss	alarm	bH	The motor is not connected
Spare	alarm	CH	Factory reserved

Undervoltage	alarm	dH	Power input is less than 18V
Overpressure	alarm	EH	Power input is greater than 60V
Overheat	alarm	FH	The temperature of the drive radiator reaches 85°C or more
MOS tube driver voltage failure	alarm	10H	MOS tube driver voltage failure
Spare	alarm	11H	Factory reserved
Spare	alarm	12H	Factory reserved
Spare	alarm	13H	Factory reserved
EEPROM data writing abnormal	alarm	14H	EEPROM data writing abnormal
Location is out of tolerance	alarm	19H	Location is out of tolerance
Current overload	alarm	1AH	Current overload
Encoder error	alarm	1BH	Encoder wiring error
Communication abnormal	alarm	64H	The communication bus is abnormal. When the device is enabled, the communication line is disconnected or the communication quality is unstable
EEPROM data read abnormal	warning	100H	EEPROM data read abnormal
Unstable bus voltage	warning	200H	Unstable bus voltage
Emergency stop	warning	400H	Emergency stop
Positive limit	warning	800H	On the positive limit or over the positive soft limit
Negative limit	warning	1000H	On the negative limit or over the negative soft limit
Back to origin failed	warning	2000H	Back to origin failed

#### 4.4 Overtravel Display

When an overtravel occurs, it is displayed as follows :

- a. forward side overtravel (P-OT)

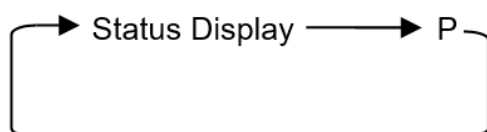

- b. reverse side overtravel (N-OT)

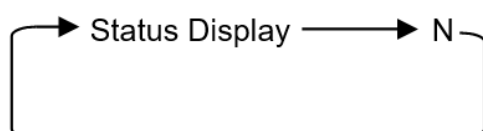

- c. forward side / reverse side overtravel occurs

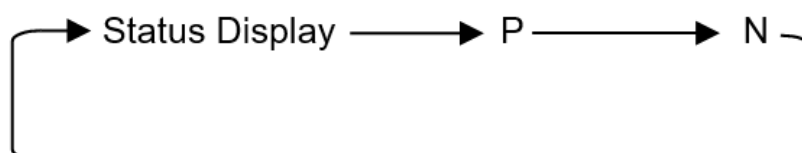

## 5. Power Supply

### 5.1 Voltage

The chopper driver continuously changes the size and direction of the motor winding voltage and detects the current to obtain accurate phase current. If both high efficiency and low noise are to be ensured, the driver supply voltage shall be at least 5 times the motor rated phase voltage (that is, the motor rated phase current  $\times$  phase resistance).

If you need the motor to get better high speed performance, you need to increase the driver supply voltage.

If power is supplied from a regulated power supply, the supply voltage shall not exceed 36V.

If non-stabilized power supply is used, the voltage shall not exceed 25V.

Because the rated current of non-stabilized power supply is full load current. When the load is light, such as when the motor is not running, the actual voltage is up to 1.4 times the rated voltage of the power supply. For smooth and quiet operation of the motor, choose low voltage.

### 5.2 Current

The maximum supply current shall be the sum of the two phase current. Usually, the amount of current you need depends on the type of motor, voltage, speed, and load conditions. The actual supply current value is much lower than this maximum value, because the driver USES a switching amplifier that converts high voltage and low voltage current into low voltage and high current. The more the supply voltage exceeds the motor voltage, the less supply current is required. When the motor is connected to a 48V power supply, the output current of the power supply is half of that of the 24V power supply.

### 5.3 Regeneration of Discharge

When the motor slows down, it ACTS like a generator, converting the kinetic energy of the load into electricity. Some energy is consumed by the driver and motor. If your application has a large load running at high speed, a considerable amount of kinetic energy can be converted into electricity. Easy to cause the drive alarm (overvoltage) may even cause damage to the drive.

## 6. Motor Connection

i

Warning

When connecting the motor to the drive, first make sure that the power of the drive is turned off. Make sure that the unused motor leads are not short-circuited with other objects. The motor cannot be disconnected while the drive is energized. Do not connect motor leads to ground or power.

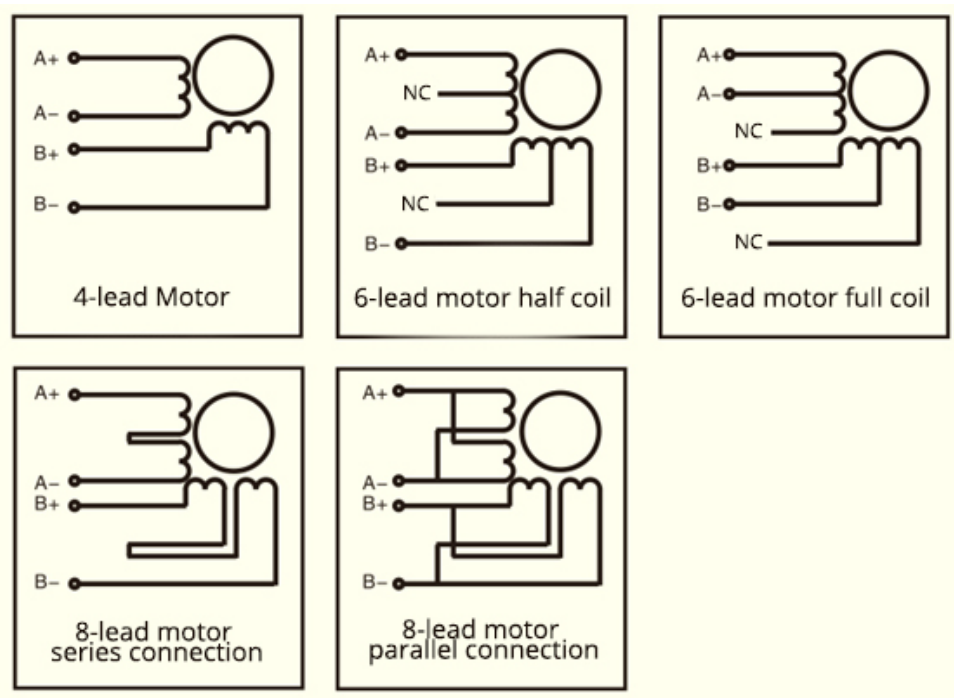

- 1) Four-wire motors can only be connected in one way.
- 2) Six-wire motors can be connected in two ways: full group and half group. In the full group mode, the motor has greater torque at low speeds, but it cannot run as fast as in the half group. When the whole group is running, the motor needs to run at less than 30% of the half-group current to avoid overheating.
- 3) Eight-wire motors can be connected in two ways: series and parallel. The series mode has greater torque at low speeds and less torque at high speeds. When running in series, the motor needs to run at 50% of the current in parallel to avoid overheating

i

Notes

- 1) The corresponding colors of different motors are different. When using the motors, the specifications of the motors shall prevail. For example, the colors of 57 and 86 motor wires are different.
- 2) The phases are relative, but the windings of different phases cannot be connected to the terminals of the same phase of the driver (A +, A- is one phase, B +, B- is the other phase). If the motor direction is different from the expected direction, only A +, A-.
- 3) This driver can only drive two-phase hybrid stepping motors, not three-phase and five-phase stepping motors.
- 4) The method of judging whether the stepper motor is connected in series or in parallel: Rotate the shaft of the motor directly by hand without connecting the driver. If it can rotate easily and evenly, it means that the wiring is correct. If it encounters large resistance and unevenness Accompanied by a certain sound indicating that the wiring is incorrect.

## 7. Typical Signal Connection

### 7.1 Common Positive Connection

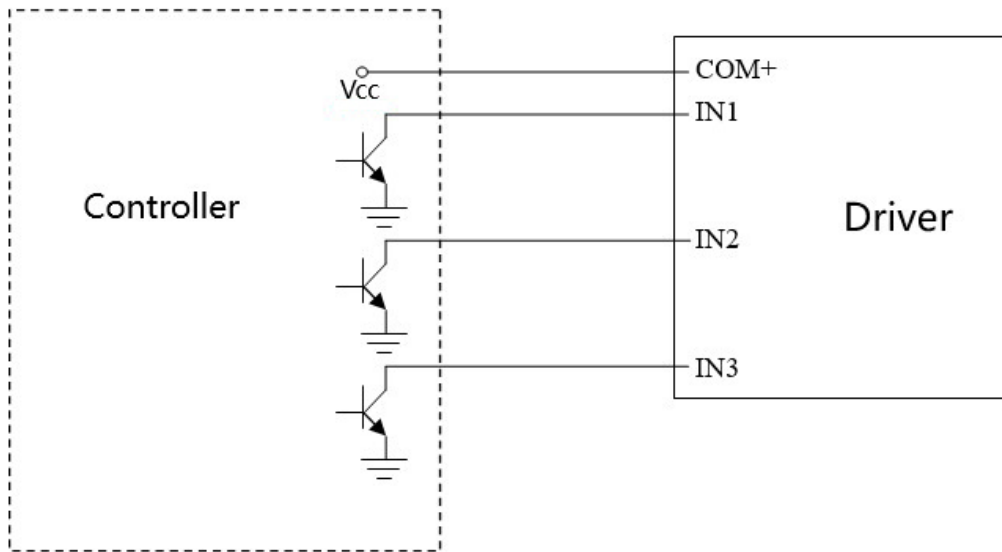

### 7.2 Common Cathode Connection of Output Signal

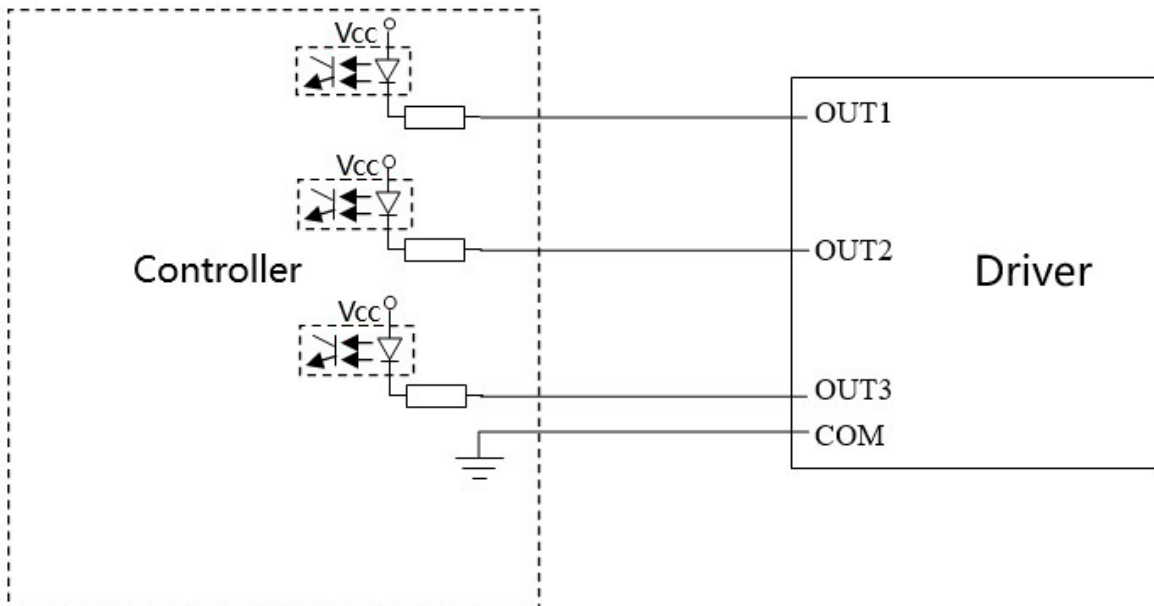

## 8. Wiring Requirements

- 1) In order to prevent the driver from being disturbed, it is recommended to use shielded cable for the control signal, and the shield layer should be shorted to the ground. Except for special requirements, the shielded wire of the control signal cable is grounded at one end: the upper end of the shielded cable is grounded. The driver end of the wire is left floating. Grounding can only be performed at the same point in the same machine. If it is not a real ground wire, the interference may be serious, and the shielding layer is not connected at this time.
- 2) Pulse and direction signal lines and motor lines are not allowed to be bundled side by side, preferably at least 10cm apart, otherwise motor noise may easily interfere with pulse direction signals, causing inaccurate positioning of the motor, system instability and other faults.
- 3) If one power supply is used for multiple drives, a parallel connection should be adopted at the power supply. It is not allowed to connect one to the other in a chain.
- 4) It is strictly forbidden to plug and unplug the driver's strong current (motor and power) terminals. When the charged motor is stopped, a large current still flows through the coil. Plugging and unplugging the strong current (motor and power) terminals will cause a huge momentary induced electromotive force to burn out. driver
- 5) It is strictly forbidden to add lead to the terminal after adding tin, otherwise the terminal may be damaged due to overheating due to the increased contact resistance.
- 6) The wiring head must not be exposed outside the terminal to prevent the driver from being accidentally shorted.

## 9. Installation Dimensions (unit : mm)

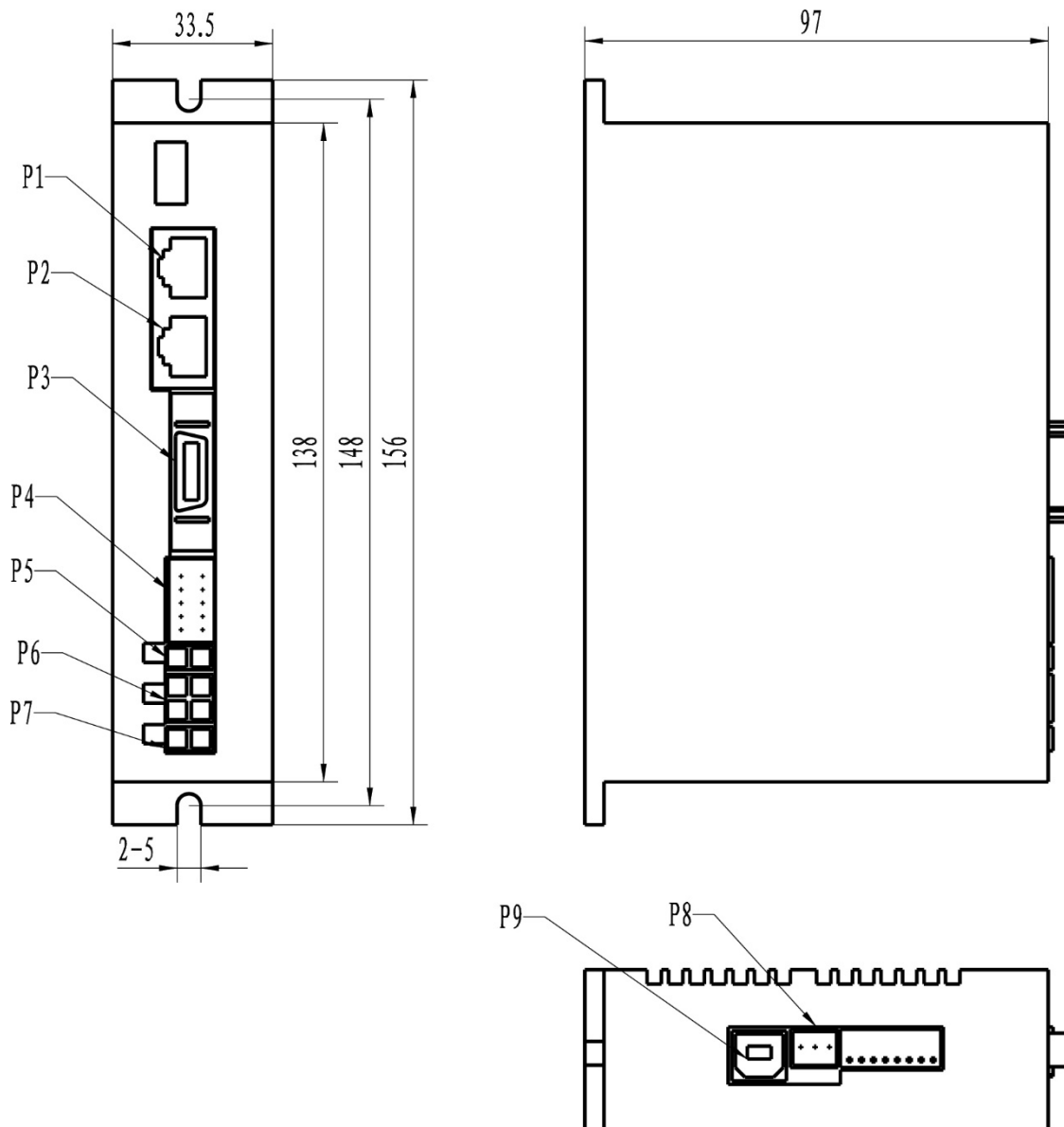

### drive installation

Use the narrow side to install and use M4 screws to install through the holes on both sides. The power device of the driver will generate heat. If it continuously works under the condition of high input voltage and high power, the effective heat dissipation area should be enlarged or forced cooling.

Do not use it in a place with no ventilation or where the ambient temperature exceeds 40°C; do not install the driver in a place with damp or metal chips.

## 10. CANopen Communication

### 10.1 CANopen Communications Service

CANopen specifications followed by the product :

- follow standards CAN2.0A
- Compliance with CANopen Standard Agreement DS301V4.02
- Compliance with CANopen Standard Agreement DSP402V2.01

Services supported by the CANopen drive :

- Support NMT Slave service
- Device monitoring: support heartbeat packets and node protection
- Support for PDO services: each slave station can be configured with up to 4 TXPDos and 4 RXPdos
- PDO transport types: event trigger, time trigger, synchronous cycle, synchronous non-cycle
- Support for SDO services
- Support for Emergency Protocol

### 10.2 CANopen Communication Object Identifier

The communication object identifier (COB-ID) is used to specify the priority of the communication object and its identification.

The 11-bit CAN-ID contains the 4-bit function code part and the 7-bit Node ID(Node-ID) part, as shown in the figure below :

Functional code				id of nodes						
10	9	8	7	6	5	4	3	2	1	0

The Node-ID range is 1 to 127(0 is not allowed).

Each communication object of CANopen has a default COB-ID, which can be read through SDO, and parts can be modified through SDO.right

As shown in the list below :

CANopen predefines a master/slave connection set of broadcast objects				
Object	Functional code	Node address	cob-id	Object Dictionary Index
NMT network management	0000	0	0x000	-
Synchronization	0001	0	0x080	1005H,1006H,1007H



object				
Emergency	0001	1~127	0x081~0x0FF	1024H,1015H
TXPDO1 (send)	0011	1~127	0x181~0x1FF	1800H
RXPDO1 (receive)	0100	1~127	0x201~0x27F	1400H
TXPDO2 (send)	0101	1~127	0x281~0x2FF	1801H
RXPDO2 (receive)	0110	1~127	0x301~0x37F	1401H
TXPDO3 (send)	0111	1~127	0x381~0x3FF	1802H
RXPDO3 (receive)	1000	1~127	0x401~0x47F	1402H
TXPDO4 (send)	1001	1~127	0x481~0x4FF	1803H
RXPDO4 (receive)	1010	1~127	0x501~0x57F	1403H
TSDO(Server send)	1011	1~127	0x581~0x5FF	1200H
TXPDO1 (send)	1100	1~127	0x601~0x67F	1200H
RXPDO1 (receive)	1110	1~127	0x701~0x77F	1016H~1017H



## Notes

- 1) PDO/SDO send/receive is relative to slave CAN node side.
- 2) NMT fault control includes Node protection, Heartbeat and boot-up protocols.
- 3) The ID address allocation table corresponds to a predefined set of master-slave connections, and because all peer ids are different, there is actually only one master device known.

All connected node ids can communicate with each connected slave node (up to 127) in a peer-to-peer manner. Two slave nodes connected together cannot communicate.

## 10.3 Object Dictionary (OD)

### 10.3.1 Object Dictionary Overview

An Object Dictionary is an ordered group of objects. Each object is addressed with a 16-bit index in order to allow access

A single element in the data structure defines an 8-bit sub-index. The structure of the object dictionary is shown in the following table:

Index	Object
0000H	Don't use
0001H—001FH	Standard data types such as Boolean (Bool), Integer16, etc
0020H—003FH	Complex data types such as PDO communication parameters (PDOCommpar)
0040H—005FH	The responsible data type specified by the manufacturer
0060H—007FH	Standard data types specified in the device subprotocol
0080H—009FH	A complex data type specified by a device subprotocol
00A0H—0FFFH	Reserved area
1000H—1FFFH	Communicate sub-protocol areas, such as device type, PDO number, etc
2000H—5FFFH	Manufacturer specific sub-protocol area
6000H—9FFFH	Standard device sub-protocol areas, such as the object dictionary area of DSP 402
A000H—FFFFH	Reserved area

The detailed definition of the object dictionary is described in electronic Data Documents (EDS) and EDS can be obtained by contacting our technology.

The three main object dictionaries in EDS are described as follows:

- (1) Communication object dictionaries, such as 1000H, 1400H, 1A00H and other object dictionaries;
- (2) Custom object dictionary of the manufacturer, such as 2000H-2130h;
- (3) CIA DSP402 section object dictionary.

### 10.3.2 Object Type

The CANopen object code corresponding to the "object" column in the above table is shown in the following table:

Object name	Object code	Note
NULL	0	No data
DOMAIN	2	Large amounts of data, such as executable code snippets
VAR	7	Variables, such as Boolean, are of unsigned 8-bit type
ARRAY	8	Arrays, lots of data of the same type
RECORD	9	Records can be a large number of different types of data

### 10.3.3 Access Properties

Property	Note
RW	Read/write
WO	Just write
RO	read-only
CONST	Constant, read-only

### 10.3.4 Communication Object Dictionary

The communication class object dictionary list is as follows:

Index	Object type	Name of name	Data type	Access properties
1000H	VAR	Device type	Unsigned 32 bits	RO
1001H	VAR	Error register	Unsigned 8 bits	RO
1003H	ARRAY	Predefined error area	Unsigned 32 bits	RO
1005H	VAR	The PDO synchronous ID	Unsigned 32 bits	RW
1006H	VAR	Communication cycle	Unsigned 32 bits	RW
1007H	VAR	PDO time window	Unsigned 32 bits	RW
1008H	DOMAIN	Device name	string	CONST
1009H	VAR	Hardware version	string	CONST
100AH	VAR	Software version	string	CONST

1014H	VAR	Emergency message	Unsigned 32 bits	RW
1017H	VAR	Producer heartbeat time	Unsigned 16 bits	RW
1018H	RECORD	Identifies objects	Unsigned 32 bits	RO
1200H	RECORD	Server SDO parameters	Server SDO parameters	RO
1400H	RECORD	Receive the PDO parameter	Receive the PDO parameter	RW
1402H	RECORD	Receive the PDO parameter	Receive the PDO parameter	RW
1403H	RECORD	Receive the PDO parameter	Receive the PDO parameter	RW
1600H	RECORD	Receive the PDO map	Receive the PDO map	RW
1602H	RECORD	Receive the PDO map	Receive the PDO map	RW
1603H	RECORD	Receive the PDO map	Receive the PDO map	RW
1800H	RECORD	Send the PDO parameter	Send the PDO parameter	RW
1802H	RECORD	Send the PDO	Send the PDO	RW
1803H	RECORD	Send the PDO parameter	Send the PDO parameter	RW
1A00H	RECORD	Send the PDO map	Send the PDO map	RW
1A02H	RECORD	Send the PDO map	Send the PDO map	RW
1A03H	RECORD	Send the PDO map	Send the PDO map	RW

## 10.4 Network Management (NMT)

NMT provides network management services. This service is implemented in a master-slave communication mode (so there is only one NMT master node).

Only NMT master node can transmit NMT module control message, all slave nodes must support NMT module control service, and NMT module control does not need reply. The message format is as follows:

NMT master node → NMT slave node

COB-ID	Byte 0	Byte 1
0x000	Command word	Node-ID

When Node-ID=0, all NMT slave nodes are addressed. The corresponding relationship between the value of the command word and the service is shown in the following table:

Command Word	NMT service
1(01H)	Start remote node
2(02H)	Stop remote node
128(80H)	Enter the pre-operation state
129(81H)	Nodes reset
130(82H)	Communication is reset

## 10.5 NMT Error Control

NMT error control is mainly used to detect whether the device in the network is online and the state of the device, including node protection, lifetime protection and heartbeat.



### Notes

- 1) Node protection and heartbeat cannot be used simultaneously.
- 2) Node protection. The heartbeat time should not be set too short to avoid increasing network load.

### 10.5.1 Node / Lifetime Protection

Node protection is used to query the state of NMT slave machine periodically through remote frames. Lifetime protection is received from the station to monitor the slave station.

Remote frame intervals are used to indirectly monitor the state of the master station, node protection follows the master-slave model, and each remote frame must be answered.

Objects related to node/lifetime protection include protection time 100Ch and life factor 100Dh. The value of 100Ch is the node protection distance under normal circumstances.

The interval, in ms, the product of 100Ch and 100Dh determines the latest time for the host query. Under normal circumstances, node protection is possible.

Activate the lifetime protection when the nodes 100Ch and 100Dh are non-zero and are subject to a frame node protection request frame.

The master station sends the node to protect the remote frame every 100Ch, and the slave must reply, otherwise the line will be considered dropped from the station. Time from station  $100Ch \cdot 100Dh$ .

If no node protection remote frame is received, the master station is considered to be offline.

Through this service, the NMT master node can check the current state of each node. The master node sends remote frames in the following format:

NMT master node → NMT slave node

COB-ID
0x700+Node-ID

The format of NMT slave reply message is as follows:

NMT slave node → NMT master node

COB-ID	Byte 0
0x700+Node-ID	Bit 6:0 state

The data portion includes a trigger bit (Bit7) that must be interchanged with either a "0" or a "1" in each node-protection reply. The trigger bit is set to "0" on the first node protection request.

Bit 0 in position 6 (BITS0 ~ 6) represents the node state, and the corresponding relationship between its value and state is shown in the table below:

Value	State
0(00H)	Initialize the
1(01H)	Not connected
2(02H)	The connection
3(03H)	prepare
4(04H)	stop
5(05H)	operation
127(7FH)	pre-operational



### Notes

If node / lifetime protection is used, 100C is recommended to be greater than 10ms and 100D is recommended to be greater than 2.

## 10.5.2 The Heartbeat

A node may be configured to produce periodic packets called heartbeats. The heartbeat model uses a producer-consumer model. CANopen device can send heartbeat packets according to the cycle set by the producer heartbeat interval object 1017h, in ms. Nodes with consumer heartbeat function in the network will be monitored according to the consumer time set by the object 1016h. Once the heartbeat of the producer of the corresponding node is not received within the range of consumer heartbeat time, the node will be considered to be disconnected (or there is a fault).

After the manufacturer's heartbeat interval was configured for 1017h, the node's heartbeat function was activated and heartbeat packets were generated. After configuring a valid sub-index of consumer heartbeat for 1016h, monitoring begins when a frame of heartbeat is received from the corresponding node.

The host sends heartbeat packets according to the producer's time. If the slave monitoring the host does not receive heartbeat packets within 1016h sub-index time, the host is considered to have dropped the station.  $1016h \text{ a sub-index time} \geq \text{host producer time} \times 2$ , otherwise it is easy to misreport from the machine and consider the host to drop the station.

The slave shall send heartbeat packets every 1017h to monitor the slave's host (or other slave). If the slave fails to receive the heartbeat packets within the consumer's time, the slave shall be considered to have dropped the station.  $1017h \times 2 \leq \text{monitoring the consumer time of the slave's host machine (or other slave machine)}$ , otherwise it is easy to misreport the slave station.

The format of the heartbeat message is shown in the table. The data segment contains only one byte, and the others are consistent with the status of the node protection reply message

in the table.

Heartbeat producer → consumer

COB-ID	Byte 0
0x700+Node-ID	state

The corresponding meaning of its value is shown in the following table:

State value	Meaning
0(00H)	Initialize the
4(04H)	stop
5(05H)	operation
127(7FH)	pre-operational

**Notes** The driver is the heartbeat producer. It is recommended that the duration of the heartbeat producer should not be less than 20ms.

### 10.5.3 Communication State Machine

The communication state machine of CANopen is shown in the following figure:

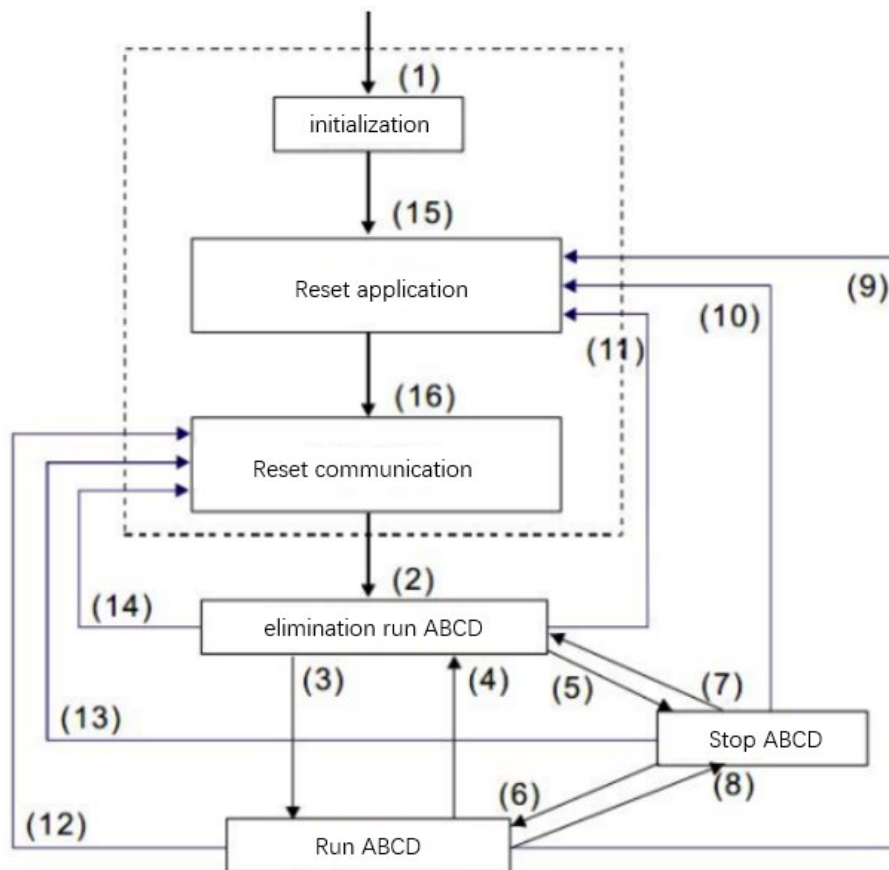

**Description :**

(1) After the power is turned on, it will automatically enter the initialization state A: NMT

(2) Automatically enter the pre-operation state B: Node Guard

(3) (6) Start the remote node C: SDO

Enter into pre-operation (pre-operation) state D: Emergency

(5) (8) Stop remote node E: PDO

Reset the node F: Boot-up

Reset the communication

(15) Automatically enter the reset application state

(16) Automatically enter the reset communication state

Device initialization (the general term for initialization, reset application and reset communication in the figure) is completed and then enters the pre-operation state. Devices in this state can be passed.

Sdos (such as using configuration tools) set parameters and assign ids. The node then goes directly into the operational state.

## 10.6 Service Data Object (SDO)

SDO is used to access a device's object dictionary. A visitor is called a client, and the object dictionary is accessed and provides the requested service

A CANopen device is referred to as a server. The client's CAN message and the server's reply CAN message always contain 8 bytes of data (although not all data bytes are necessarily meaningful). A customer's request must have an answer from the server.

Its basic structure is as follows:

Client → server/server → Client

Byte 0	Byte 1:2	Byte 3	Byte 4:7
SDO command word	An object	Object subindex	data

Example: Use the SDO message to write the value 0x20F0 to an object dictionary with an index of ID 2 of 1801H and a subindex of 3.

COB-ID	Byte 0	Byte 1	Byte 2	Byte 3	Byte 4	Byte 5	Byte 6	Byte 7
Client → server								
602	2B	01	18	03	F0	20	00	00
server → Client								
582	60	01	18	03	00	00	00	00

Use the following SDO message to read the data of an object whose index is 1801H and whose subindex is 3 in the object dictionary.

COB-ID	Byte 0	Byte 1	Byte 2	Byte 3	Byte 4	Byte 5	Byte 6	Byte 7
Client → server								
602	40	01	18	03	00	00	00	00
server → Client								
582	4B	01	18	03	F0	20	00	00

The SDO client or server aborts SDO transmission by sending a message in the following format:

Client → server/server → Client

Bit	7	6	5	4	3	2	1	0
	1	0	0	-	-	-	-	-

In the SDO abort message, bytes 0 and 1 represent the object index, and bytes 2 represent the subindex. Bytes 4 to 7 contain 32-bit abort codes, which describe the cause of the abort.

## 10.7 Process Data Object (PDO)

### 10.7.1 Transmission Framework and Features of PDO

The Process Data Object (PDO) is used to transmit data in real time and is the main data transmission mode in CANopen. PDO adopts the producer/consumer mode. The length of PDO can be less than 8 bytes, and the transmission speed is relatively fast. PDO data transmission can be one-to-one or one-to-many. Each PDO information includes sending PDO(TxPDO) and receiving PDO(RxPDO) information, and the transmission mode is defined in the PDO communication parameter index.

All PDO transfers must be mapped to the corresponding index area through the object dictionary image. Take the 1600H and 1A00H objects defined in DSP 402 as examples:



#### Notes

The value of the object dictionary in the figure is only needed for example, and does not have practical significance.

The master station sends messages to the slave station PDO

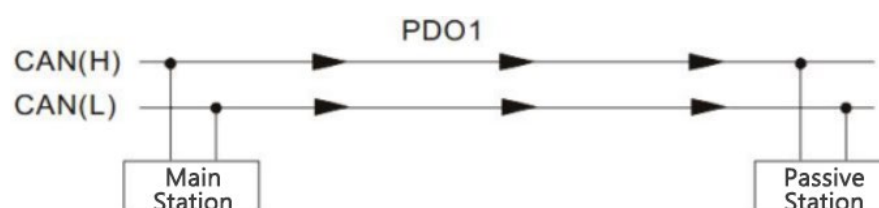



PDO1 data value Data 0, Data 1, Data 2, Data 3, Data 4, Data 5, Data 6, Data 7, 0x77, 0x88,

Index	Sub	Definition	Value	R/W	Size
0x1600	0	0. Number	1	R/W	U8
0x1600	1	1. Mapped Object	0x60400010	R/W	U32
0x1600	2	2. Mapped Object	0	R/W	U32
0x1600	3	3. Mapped Object	0	R/W	U32
0x1600	4	4. Mapped Object	0	R/W	U32
0x6040	0	0. Control word	0x2211	R/W	U16 (2 Byte)

*Note: The value 0x60400010 is circled in the original image and points to the 'Value' column of the 0x1600.1 entry and the 'Index' column of the 0x6040.0 entry.*

The following figure describes in detail the relationship between PDO parameters (1400H) and PDO mapping (1600H) and the transmission process of PDO data (take Node 2 as an example). The direction of the arrow shown in the figure indicates the direction of data processing of the master station.

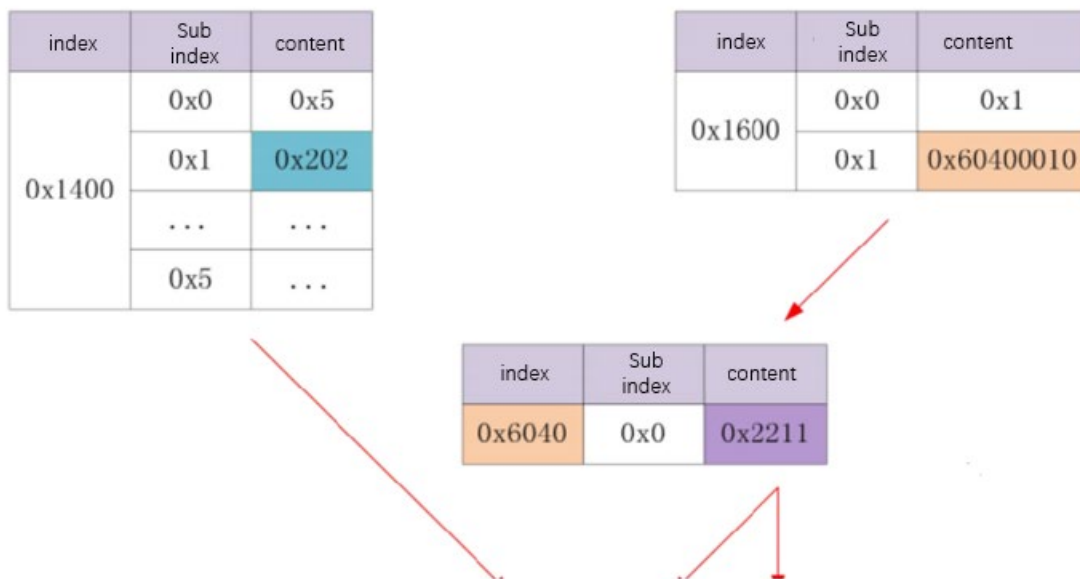

The master station receives the information returned from the station

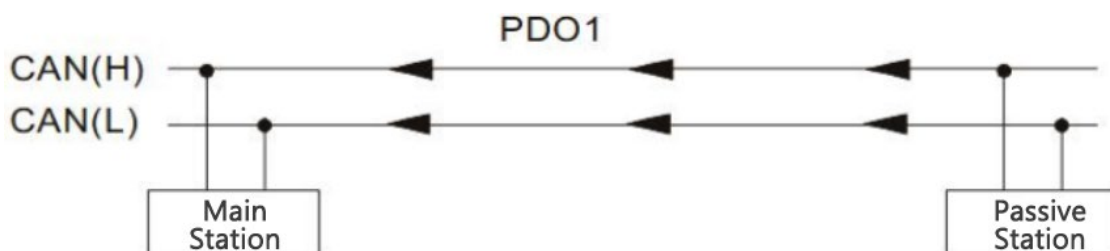

PDO1 data value Data 0, Data 1, Data 2, Data 3, Data 4, Data 5, Data 6, Data 7,  
0xF3, 0x00,

Index	Sub	Definition	Value	R/W	Size
0x1A00	0	0. Number	1	R/W	U8
0x1A00	1	1. Mapped Object	0x60410010	R/W	U32
0x1A00	2	2. Mapped Object	0	R/W	U32
0x1A00	3	3. Mapped Object	0	R/W	U32
0x1A00	4	4. Mapped Object	0	R/W	U32
0x6041	0	Statusword	0xF3	R/W	U16

PDO1 Map

The following figure describes in detail the relationship between PDO parameters (1800H) and PDO mapping (1A00H) and the transmission process of PDO data (take Node 2 as an example). The direction of the arrow shown in the figure indicates the direction of slave station data processing.

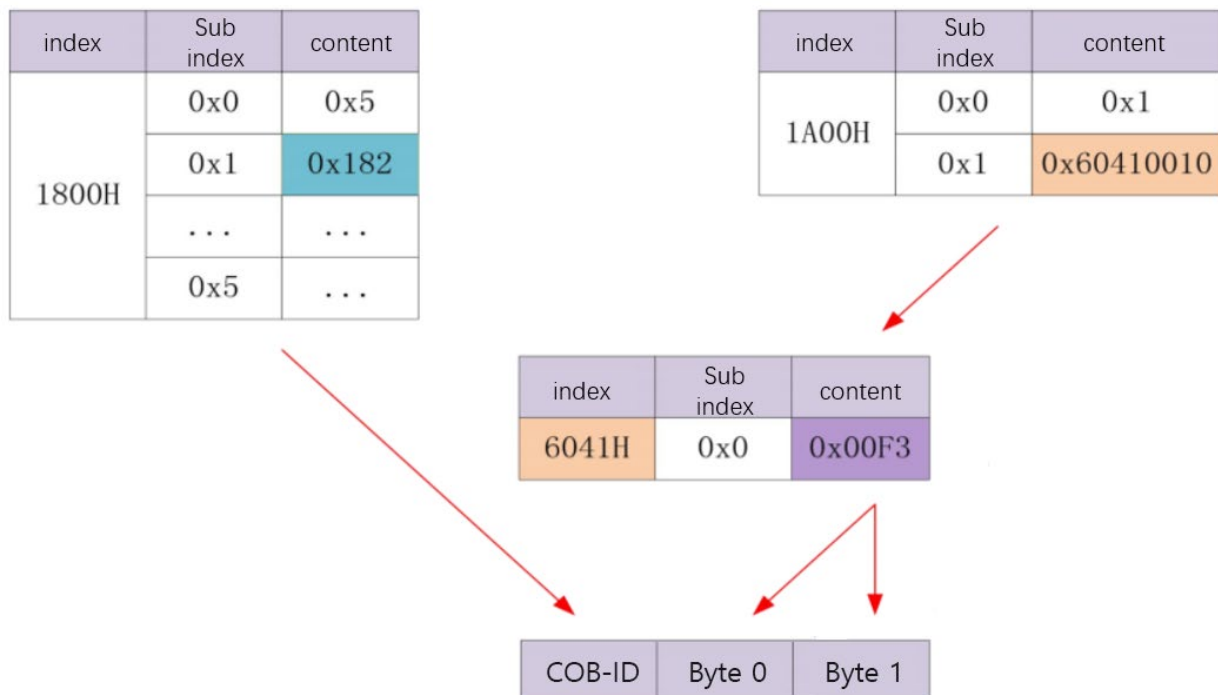

In this product, CANopen communication only supports point-to-point PDO transmission.

### 10.7.2 The PDO Object

According to the difference of receiving and sending, note that PDO is divided into TPDO and RPDO for slave stations. Four TPDO and four RPDO are used. The list of related objects is as follows:

object	function code	COB-ID	Communication object	Mapping object
TXPDO1 (send)	0011	0x181~0x1FF	1800H	1A00H
RXPDO1 (receive)	0100	0x201~0x27F	1400H	1600H
TXPDO2 (send)	0101	0x281~0x2FF	1801H	1A01H
RXPDO2 (receive)	0110	0x301~0x37F	1401H	1601H
TXPDO3 (send)	0111	0x381~0x3FF	1802H	1A02H
RXPDO3 (receive)	1000	0x401~0x47F	1402H	1602H
TXPDO4 (send)	1001	0x481~0x4FF	1803H	1A03H
RXPDO4 (receive)	1010	0x501~0x57F	1403H	1603H

### 10.7.3 Communication Parameters of PDO

#### 1) CAN identifier of PDO

The CAN identifier of PDO, namely the COB-ID of PDO, contains the control bit and identification data to determine the bus priority of the PDO. The COB-ID is located on the sub-index 01 of the communication parameter (RPDO: 1400h~1403h, TPDO: 1800h~1803h), and the highest bit determines whether the PDO is valid.

The drive only supports point-to-point PDO transmission, so the coB-ID low by 7 bits must be the station address of the node.

#### 2) Transmission type of PDO

The transmission type of PDO is located on the subindex 02 of the communication parameter (RPDO: 1400h~1403h, TPDO: 1800h~1803h)

Asynchronous transmission - transmission triggered by events, including data change trigger, periodic event timer trigger.

Synchronous transmission - The connection between synchronous frames in a network. Communication parameters (RPDO: 1400h~1403h, TPDO: 1800h~1803h) subindex 02 Different values represent different transmission types, defined.

The method that triggers TPDO to transmit or process the received RPDO is shown in the table.

Communication type value	Synchronous		asynchronous
	Cyclic	acyclic	
0		√	
1 ~ 240	√		
241 ~ 254		Reservations	
254, 255			√

**Description:**

- 1) When the TRANSMISSION type of TPDO is 0, if the data of the mapped object changes and a synchronous frame is received, the TPDO is sent.
- 2) When the transmission type of TPDO is 1~240, the corresponding number of synchronous frames are received and the TPDO is sent.
- 3) When the transport type of TPDO is 254 or 255, the TPDO is sent when the mapping data changes or the event timer arrives.
- 4) When the transmission type of RPDO is 0~240, update the latest data of the RPDO to the application as long as a synchronous frame is received; When the RPDO transport type is 254 or 255, the received data is updated directly to the application.

## 5) No time

The forbidden time is set for TPDO, which is stored on the sub-index 03 of the communication parameter (1800h~1803h) to prevent the CAN network from being continuously occupied by PDO with lower priority. The unit of this parameter is 100US. After setting the value, the transmission interval of the same TPDO shall not be less than the time corresponding to this parameter.

For example, if TPDO2 has a forbidden time of 300, the transmission interval of TPDO will not be less than 30ms.

Suggestion: When frequently changing objects (such as feedback position, feedback speed, etc.) are configured to TPDO, and the transmission type of the TPDO is asynchronous, it is recommended to set a certain time of prohibition.

## 6) Event timer

An event timer is defined for TPDO with an asynchronous transport (of type 254 or 255) on a subindex 05 of the communication parameter (1800h~1803h). An event timer can also be thought of as a trigger event, which also triggers the corresponding TPDO transport. If other events, such as data changes, occur during the timer cycle, TPDO also fires, and the event counter is reset immediately.

## 7) Configuration suggestions for PDO properties

(1) Synchronous or asynchronous: Synchronous transmission means that the data corresponding to PDO is updated when the synchronous frame is generated on the bus. Its characteristic is that the data update cycle is stable, but it cannot keep synchronous with the data changes in real time. Asynchronous data update is immediately once the index according to the change, the transmission way of quick response but for frequent changes of data (location) according to the facts, etc., have larger data load on the bus easily, so often configuration a ban on time parameter (after the data is not successful, interval is a time to send again, rather than repeatedly uninterrupted send) in order to

reduce the network load.

Therefore, it is recommended to use synchronous PDO for the parameters with low real-time requirements in the network, and asynchronous PDO for the parameters with high real-time requirements, but pay attention to the configuration of the forbidden time, so as to protect the network load from impact.

- (2) Setting of synchronization cycle: It is recommended to calculate according to empirical formula (default baud rate of 1M) :

Synchronization period (ms) = [PDO total / 9] / (40%) + 2

Suppose a CANopen network has 12 axes, each with one send and one receive PDO. So the total number of Pdos is 12\*2=24. Transport every millisecond bus capacity situations about 9 PDO, considering bus load margin, assuming that the bus load is 40% (relatively reasonable load factor), the time needed for 24 PDO transmission for: (40%) = 6.67/24/9 (ms), SDO, considering the network synchronization time frame, the heartbeat message, such as emergency message overhead, add 2 milliseconds, recommended configuration synchronization cycle is 8.67 milliseconds.

The above empirical formula also applies to setting the disable time of asynchronous PDO.

#### 10.7.4 PDO Mapping Parameters

The PDO mapping parameter contains a pointer to the process data corresponding to PDO that PDO needs to send or receive, including the index, sub-index, and length of the mapped object. Each PDO data can be up to 8 bytes long and can map one or more objects simultaneously. Where sub-index 0 records the number of objects in the specific mapping of the PDO, and sub-index 1~8 is the mapping content. The mapping parameter content is defined as follows.

<b>Position</b>	31	... ..	16	15	... ..	8	7	... ..	0
<b>Definition</b>	Index		Sub-index			Object length			

Index and sub-index jointly determine the position of the object in the object dictionary. The length of the object indicates the specific bit length of the object, which is expressed in hexadecimal, namely:

The object length	bit length
08h	8
10h	16
20h	32

## 10.8 Synchronization Object (SYNC)

A synchronization object (SYNC) is a special mechanism that controls the harmony and synchronization between multiple nodes' sends and receives for PDO synchronization transfers. The configuration process of synchronization generator is as follows:

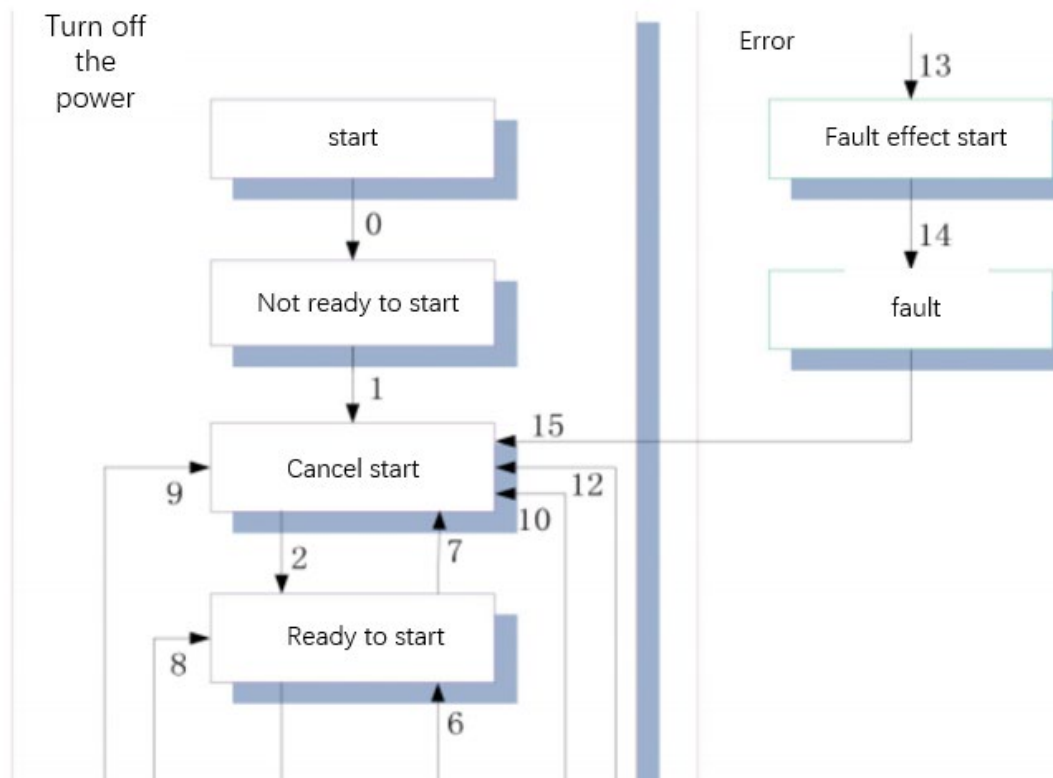

Drive synchronization cycles of less than 2ms are not recommended.

### 10.8.1 Sync Generator

A driver is both a synchronization consumer and a synchronization producer. The synchronization related objects that are supported are the synchronization object COB-ID (1005h) and the synchronization cycle (1006h).

The secondary level of the synchronization object COB-ID determines whether the synchronization generator is activated.

### 10.8.2 Transmission Framework for synchronous objects

Similar to the transmission of PDO, the transmission of the synchronous object follows the producer-consumer model, in which the synchronous producer issues the synchronous frame, and all other nodes in the CAN network CAN receive the synchronous frame as the consumer

without feedback. Only one active sync generator is allowed in the same CAN network.

The transmission of synchronous PDO is closely related to synchronous frames.

- For synchronous RPDO, as long as the PDO is received, the received PDO is updated to the application at the next SYNC.
- For synchronous TPDO, it can be divided into synchronous cycle and synchronous non-cycle, as shown in the following table:

Type		Note
Synchronous TPDO	Synchronous acyclic	The PDO transport type is 0, the PDO mapped object content changes and is sent at the next SYNC.
	Synchronous cycle	The TRANSMISSION type of PDO is 1~240, and the TPDO needs to be sent whenever the SYNC specified by the transmission type is reached, regardless of whether the data has changed

## 10.9 Emergency Target Service (EMCY)

When an error occurs in the CANopen node, the node will send a frame of emergency message according to the standardization mechanism.

The emergency message follows the producer-consumer model. After a node failure is sent, other nodes in the CAN network CAN choose to handle the failure.

Drivers act as emergency message producers only and do not process emergency messages from other nodes.

An object associated with an emergency message	Description
Error register (1001h)	Reflect the general error status of the node, each bit is classified according to the corresponding error
Scheduled at error field (1003h)	Save the most recent error

The emergency instruction message is triggered by a fatal error in the device and is sent to other devices with the highest priority by the relevant application device. Suitable for interrupt type error warning signals.

An emergency message consists of 8 bytes. The format is as follows:

Sending end → receiving end

COB-ID	Byte 0:1	Byte 2	Byte 3:7
0x080+Node-ID	Emergency error code	Error register (1001h)	Manufacturer designated area

Emergency error code supported

Recent errors are stored in the "Booked in error Field" object dictionary (index 1003H). Users can read this information through SDO. But if the drive fails, these error messages are not saved. The current error type is stored in the object dictionary error register (index 1001H). The device can map internal errors to this status byte and can quickly see the current error type.

The following table defines the error register bits

Position	Wrong type
0	General error
1	current
2	voltage
3	The temperature
4	communication
5	Error specified in device Protocol (402)
6	keep
7	Vendor designation error

## 11. Parameter Description and Setting

### 11.1 SDO Parameters List

The bus closed loop stepping driver is a standard CANopen slave station device that follows the CANopen standard protocol to communicate with the standard master station that supports the protocol.

The PC software interacts with the driver using MODBUS protocol, and the PC software can modify/read all the driver parameters, alarm information and control the pilot run of the driver.

#### 11.1.1 Configuration Parameters

The object of a dictionary	Name of name	Property	Word	Scope	Default	Unit	Remarks
2064	Integrated current	RO	1	0~65535	--	0.1%A	
2065	Bus voltage	RO	1	0~65535	--	1%V	
206C	Error code	RO	1	0~65535	--		
206D	Running state	RO	1	0~65535	--		
206E	Hardware version	RO	1	0~65535	--		
206F	Software version	RO	1	0~65535	--		



207E	Actual location	RO	1	0~65535	--	
20C8	Current loop Kp	RW	1	50~30000	800	
20C9	Running direction	RW	1	0~3	0	Select motor running direction and set encoder direction: Bit1 =0: do not change the direction of encoder; Bit1 =1: Change the direction of encoder; Bit0 =0: do not change the running direction, bit0=1: Change the running direction.
20CE	Control command	RW	1	0~5	0	
20D5	The idle current	RW	1	10~120	50	Stop current is the percentage of running current.
20D7	Current loop Ki	RW	1	50~30000	800	
20D9	Motor mode setting	RW	1	0~2	0	0: Open loop, 1: Closed loop.
20DE	Kp maximum value of current ring	RW	1	50~30000	800	
20E0	Filter coefficients	RW	1	0~500	50	The smaller the value, the smoother the motor operation, but the higher the delay.
20E1	Current proportional maximum	RW	1	1000~2000	1000	
20E4	Current loop Ki maximum value	RW	1	50~30000	800	
20F1	Current Settings	RW	1	0~3000	1000	0.1%A
20F2	Resolution setting	RW	2	0~4294967296	10000	PPR
20F5	Idle current time	RW	1	0~65535	200	ms The delay time (MS) after the motor stops running and enters the semi-current state.
20F7	In scope	RW	1	1~1000	5	
20F8	Weak magnetic limit	RW	1	0~1000	500	
20FB	Speed loop Kp	RW	1	0~30000	1000	
20FC	Speed loop Ki	RW	1	0~30000	50	
20FD	Speed loop Kd	RW	1	0~30000	0	
20FE	Maximum speed					

20FF	Position loop Kp	RW	1	0~30000	500	
2100	Position loop Ki	RW	1	0~30000	1000	
2101	Position loop Kd	RW	1	0~30000	0	
2127	Automatic detection parameter	RW	1	0~1	1000	In open loop mode Whether the motor parameters are automatically detected and updated 0: Manual setting 1: Automatic detection
2190+1	IN1 function selection	RW	1	0~23	0	
2190+2	IN2 function selection	RW	1	0~23	0	
2190+3	IN3 function selection	RW	1	0~23	0	
2190+4	IN4 function selection	RW	1	0~23	0	
21A4+1	OUT1 feature selection	RW	1	100~109	101	
21AD	Input port logic	RW	1	0~65535	RW	
21AE	Output port logic	RW	1	0~256	RW	

### 11.1.2 Motion Parameter

The object of a dictionary	Name of name	Property	Word	Scope	Default	Unit	Remarks
603F	Error register	R	1	0~65535	0	--	
6040	Control word	R/W	1	0~65535	0	--	
6041	Status word	R	1	0~65535	0	--	
605A	A quick stop	R/W	1	0~65535	0	--	
6060	Operating mode	R/W	1	0-255	1	--	1—pp,3—pv,6—Home,8--CSP
6061	Operation mode display	R	1	0-255	0	--	
6064	Actual location	R	2	-2147483647~2147483647	0	pulse	
606C	The actual speed	R	2	-2147483647~2147483647	0	PRS	
607A	The target location	R/W	2	-2147483647~2147483647	0	pulse	pp mode 1 target location instruction
607D+1	Negative soft limit	R/W	2	-2000000000~2000000000	2000000000	pulse	
607D+2	Forward soft limit	R/W	2	-2000000000~2000000000	2000000000	pulse	
6080	Maximum	R/W	2	-2147483647~	3000	rpm	

	speed limit			2147483647			
6081	Trapezoidal velocity	R/W	2	-2147483647~ 2147483647	50000	PRS	pp mode 1 maximum speed
6083	The acceleration	R/W	2	-2147483647~ 2147483647	4000	PRS^2	pp,pv mode 1,3 acceleration
6084	Reduce speed	R/W	2	-2147483647~ 2147483647	4000	PRS^2	pp,pv mode 1,3 deceleration
6085	Emergency stop to slow down	R/W	2	-2147483647~ 2147483647	40000000	PRS^2	Emergency stop deceleration (PP, PV, Home)
6098	The origin way	R/W	1	0~ 100	21	--	
6099	Origin of speed	R/W	2	-2147483647~ 2147483647	50000	PRS	
609A	Zero acceleration and deceleration	R/W	2	-2147483647~ 2147483647	25000	PRS^2	
607C	Origin offset	R/W	2	-2147483647~ 2147483647	0	pulse	
60FD	Input IO status	R	2	0~ 4294967296	0	--	Enter the IO function logic state
60FE+1	Physical output on	R/W/S	2	0~ 4294967296	0	--	Master output signal control word
60FE+2	Physical output enablement	R/W/S	2	0~ 4294967296	0	--	Master output signal control word
6502	Support operation mode	R	2	0~ 4294967296	165	--	The control mode supported by the drive

## 12. Common Functions

### 12.1 Control Word and Operation Mode

The closed-loop stepper driver of this product will conduct trajectory planning according to the motion parameters sent by the master station after receiving the motion start command of the master station. In asynchronous motion mode, the motion between each motor shaft is asynchronous. The asynchronous motion mode of this product includes protocol position mode (PP), protocol velocity mode (PV) and origin mode (HM).

Regardless of the control mode, the data interaction between CANopen bus master and slave station is implemented by object dictionary. There are two data transmission modes, PDO and SDO. According to the control needs, data transmission is divided into three levels according to the real-time requirements and importance of data transmission: > is required and > is

recommended. "Must" means that in this mode, the corresponding object dictionary must be configured for PDO transport. "Suggestion" means that in this mode, the corresponding object dictionary is suggested to be configured as PDO transmission mode to ensure real-time data, so as to obtain better control requirements. If control requirements are not high, data transmission can also be done through SDO communication. "Yes" means that in this mode, the corresponding object dictionary is generally transmitted through SDO communication, and does not have to be configured as PDO. The object dictionaries associated with each control schema are shown in the table below.

Each control pattern associates an object dictionary							
Control mode	Index + Subindex	Name of name	Data Type	Visits Type	Unit	PDO Configuration	SDO Communications
PP mode (1)	607A-00h	The target location	I32	RW	P	advice	can
	6081-00h	Maximum speed	U32	RW	P	can	can
	60FF-00h	The target speed	I32	RW	P	advice	can
PV mode (3) PP mode (1)	6040-00h	Control word	U16	RW	—	advice	can
	6083-00h	The acceleration	I32	RW	P/S^2	can	can
	6084-00h	Reduce speed	U32	RW	P/S^2	can	can
HOME Mode (6)	6040-00h	Control word	U16	RW	—	advice	can
	6098-00h	Back to zero method	I8	RW	—	can	can
	6099-01h	Origin of the fast	U32	RW	P/S	can	can
	6099-02h	Origin of the slow	U32	RW	P/S	can	can
	609A-00h	Origin acceleration	U32	RW	P/S^2	can	can
	607C-00h	The origin of offset	U32	RW	P	can	can
PP, PV and HOME mode shared	6041-00h	Status word	U16	RO	—	advice	can
	6064-00h	Actual location	I32	RO	P	advice	can
	606C-00h	The actual speed	I32	RO	P/S	can	can
All modes share	60FD-00h	Digital input	U32	RO	—	advice	can
	603F-00h	Latest error code	U16	RO	P	advice	can
Other correlation parameters	6060-00h	Operating mode	I8	RW	—	can	can
	60B0-00h	The position offset	I32	RW	—	can	can
	6082-00h	Takeoff speed	U32	RW	P/S	can	can
	6085-00h	Emergency stop to slow down	U32	RW	P/S^2	can	can
	6061-00h	Operation mode display	I8	RO	—	can	can

No matter which control mode is adopted to realize the drive control of the actuator, it is inseparable from the reading and writing of two object dictionaries, control word 6040h, state word and 6041h. The master and slave stations use these two object dictionaries as the media

to realize the instruction issuing and state monitoring. The following highlights the definitions of the individual bits of the two object dictionaries.

The control word (6040h) is defined in the following table. In the left half of the table, bit4~6 and BIT8 are described. Their meanings depend on the operation mode, and they mainly control the operation, execution or stop of each mode.

The right half of the table describes bit0~3 and Bit7, which manage the state transitions of the 402 state machine to meet complex and diverse control requirements. The definition of the status word (6041h) is shown in the bit definition table of the status word (6041h).

Bit0 ~ BIT7 mainly shows the 402 state machine transition state, while Bit8 ~ BIT15 mainly shows the motion execution or stop state under each control mode.

The typical transition of the enabling state is as follows:

Initial (00 h) -- -- -- -- -- electricity (6 h) -- -- -- -- -- (h) -- -- -- -- -- enabled (0 fh) -- -- -- -- -- execution runs or suspend (depending on the operating mode, combining bit4 ~ 6 and bit8 Issue relevant control instructions).

The state transition that triggers the operation control under each control mode is shown in the state transition table of each control mode.

Control word (6040h) bit definition												
Mode /bit	15~9	8	6	5	4	7	3	2	1	0	Typical value	Action result
A total of	-	suspended	Depending on mode of operation			Error Reset	Allow operation	Quick stop	Voltage Output	Start		
PP model 1	-	Slowing down to stop	Absolute/Relative relative	Immediate trigger	New location points	0	0	1	1	1	07h	Start
PV model 3	-	Slowing down to stop	Invalid	Invalid	Invalid	0	0(x)	0	1	0(x)	02h	Come on
HM model 6	-	Slowing down to stop	Invalid	Invalid	Activation campaign	0	1	1	1	1	0fh	Enabling energy
There is no						1	0(x)	0(x)	0(x)	0(x)	80h	Correct mistakes
There is no						0	0	0	0	0	0	Initial

Additional notes for other bits:

Bit 2 quick stop trigger logic is valid for 0, note that it is distinguished from other triggered logic.

Bit 7 error reset trigger logic is valid along the rising edge.

Bit 5 immediately triggers the trigger logic that is valid along the rising edge

Status word (6041 h) bit definition								
Mode/Low 8	7	6	5	4	3	2	1	0
Shared	Reservations	Not started	Quick stop	Electricity	Error	Allow operation	Start	Ready to launch
Mode/high 8	15	14	13	12	10	8	11	9
Shared	Depending on mode of operation						Limit effectiveness	Remote
pp mode 1	Trigger response	Parameter 0	Invalid	New location points Response	Location	Abnormal stop	Hardware limits Bit valid Position	Below PreOP 0
pv mode 3	Invalid	Parameter 0	Invalid	Speed 0	Speed arrival	Quick stop		
Um mode 6	Trigger response	Parameter 0	Origin error	Origin completed	Location	Abnormal stop		

Additional notes for other bits:

When the drive is powered on, bit 4 will be set.

Bit 5 quickly stops activation and is only valid under logic 0, contrary to the logic of the other bits.

Bit 9 remote, display the state of communication state machine, 0 when ProOP is below, then the command of control word (6040h) cannot be executed.

Bit 11 limit, set only when the hardware limit is valid.

Bit 8 abnormal stop, generally effective in the hardware limit, deceleration stop and fast stop trigger state.

Bit 12 follows the master station. Under CSP, if the driver does not enable or no longer follows the command of the master station, the position is 0.

State transitions for each mode controlled operation										
	Steps	0	1	2	3	4	5	6	7	8
Mode	Action	Preparatory work	Initial	Electricity	Start	Enabling energy	Start Running	Variance	Stopping	Failure
pp mode 1	6040	Establish communication OP	00h	06h	07h	0fh	-	2fh->3fh	10fh	-
	6041		250h	231h	233h	8237h	1237h	1637h	1737h	1238h

		state and set motion parameters						-> 1237h		
pv mode 3	6040	Establish the all-OP state and set the motion parameters	00h	06h	07h	0fh	Enabled Running	Change speed Degree	10fh	-
	6041	parameters	250h	231h	233h	1637h	1637h	1637h	1737h	1638h
hm mode 6	6040	Establish the all-OP state and set the motion parameters	00h	06h	07h	0fh	1fh	Invalid	10fh	-
	6041	parameters	250h	231h	233h	8337h	237h	237h	737h	238h

Additional notes for other bits:

When PP mode changes position, the rise edge of BIT5 of control word needs to be given to start the new position movement.

## 12.2 Peak Output Current

If the motor with the frame of 42 or below is matched, the driver's output peak current must be modified before the motor is connected for the first time to prevent the motor from being burnt out by too much output current.

The output peak current can be modified through the object dictionary of the master STATION PLC, which is 0x20F1, or through the upper computer debugging software, as shown below:

20F1 <sup>o</sup>	Current setting	RW <sup>o</sup>	1 <sup>o</sup>	0~3000 <sup>o</sup>	1000 <sup>o</sup>	0.1%A <sup>o</sup>	<sup>o</sup>
-------------------	-----------------	-----------------	----------------	---------------------	-------------------	--------------------	--------------

## 13. Appendix : Return to Origin Method

This drive product supports the return to the origin mode of Z signal from 1 to 14 and 17 to 34,35. The specific definition and return to the origin process are described below.

### Method 1:

If the negative limit is invalid, the motor will move in the negative direction at high speed at the origin until the negative limit switch signal is effective. The motor will stop abruptly and start moving forward at low speed at the origin. The first one after leaving the negative limit switch will stop moving when the encoder Z signal is effective, as shown in Figure A below.

If the motor stops at the negative limit position when it starts moving at the origin, the motor will move forward at the low speed of the origin and stop the first time after leaving the negative limit switch when the encoder Z signal is in effect.

If the positive limit signal is effective during the movement, the status word (6041h) bit 13 will be effective, indicating that the origin motion is wrong, and the motor will stop immediately.

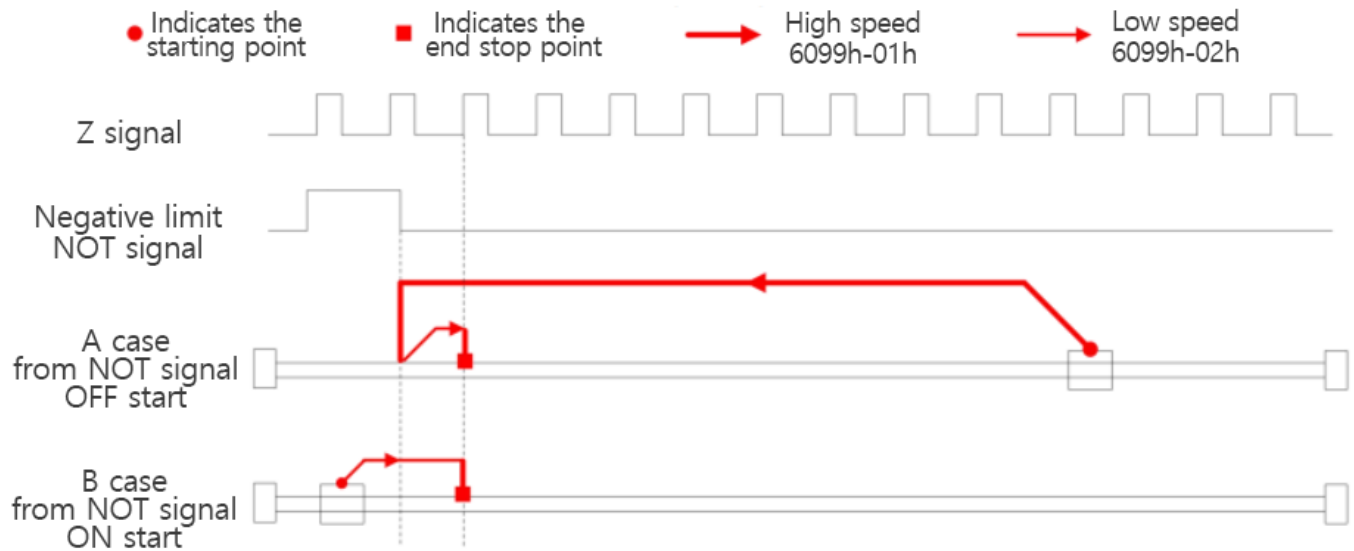

**Method 1 Diagram**

### Method 2:

If the positive limit is invalid, the motor will move in the positive direction at high speed at the origin until the positive limit switch signal is effective. The motor will stop and move at low speed at the origin in the negative direction. When the first encoder Z signal after leaving the negative limit switch is effective, the motor will stop moving, as shown in Figure A below.

If the motor stops at the positive-limit position when it starts moving at the origin, it will move at the origin low speed negatively and stop when the first Z-signal after leaving the positive-limit switch is in effect.

If the negative limit signal is effective during the movement, the status word (6041h) bit 13 will be effective, indicating that the origin motion is wrong, and the motor will stop immediately.



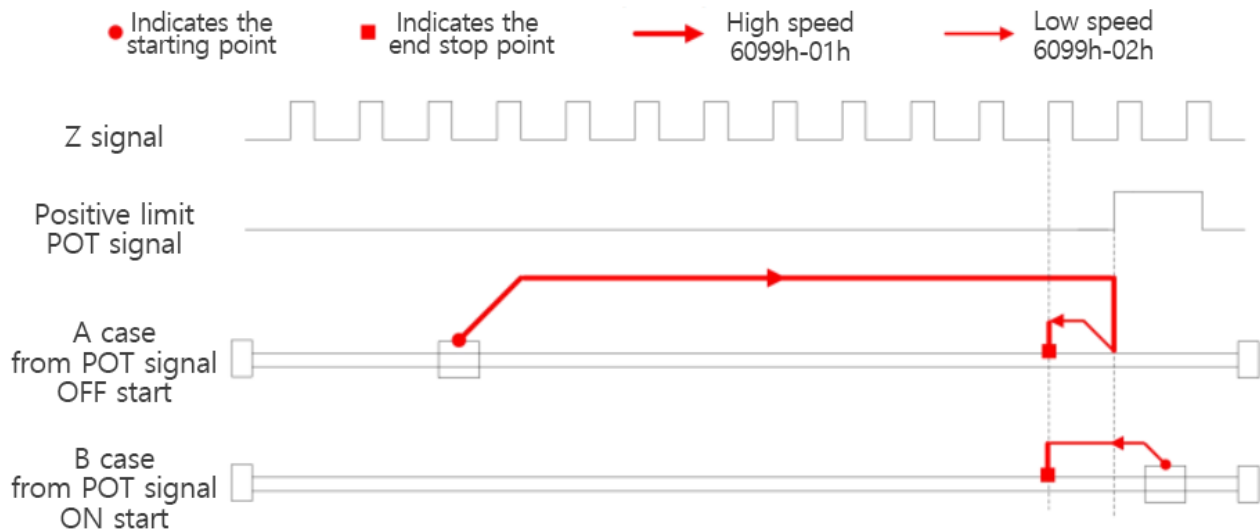

**Method 2 Diagram**

**Method 3:**

If the origin signal is invalid, the motor will move in A positive direction at A high speed at the origin until the origin signal is effective. The motor will stop and move at A low speed at the origin in A negative direction. When the first encoder Z signal after leaving the origin switch is effective, the motor will stop moving, as shown in FIG. A.

If the motor stops at the origin signal switch position when starting the origin motion, then the motor will move negatively at the origin low speed and stop when the first Z signal after leaving the origin switch is valid

If the limit signal is effective during the movement, the status word (6041h) bit 13 will be effective, indicating that the origin motion is wrong, and the motor will stop immediately.

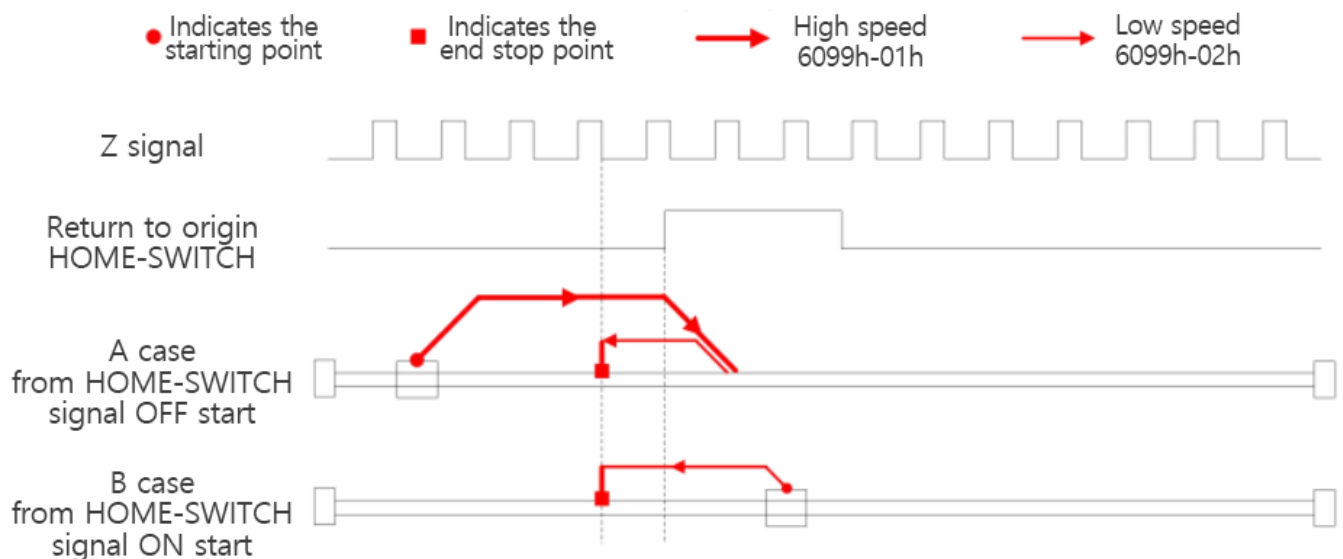

**Method 3 Diagram**

#### Method 4:

If the origin signal is invalid, the motor will move forward at low speed at the origin until the first encoder Z signal after the origin signal is valid stops, as shown in FIG. 7-4.

If the motor stops at the switch position of the origin signal when it starts to move at the origin, it will move at high speed at the origin in the negative direction until the origin signal is invalid and the motor slows down to stop and moves at low speed at the origin in the forward direction. It will stop moving when the first encoder Z signal after the origin signal is effective, as shown in Figure B.

If the limit signal is effective during the movement, the status word (6041h) bit 13 will be effective, indicating that the origin motion is wrong, and the motor will stop immediately.

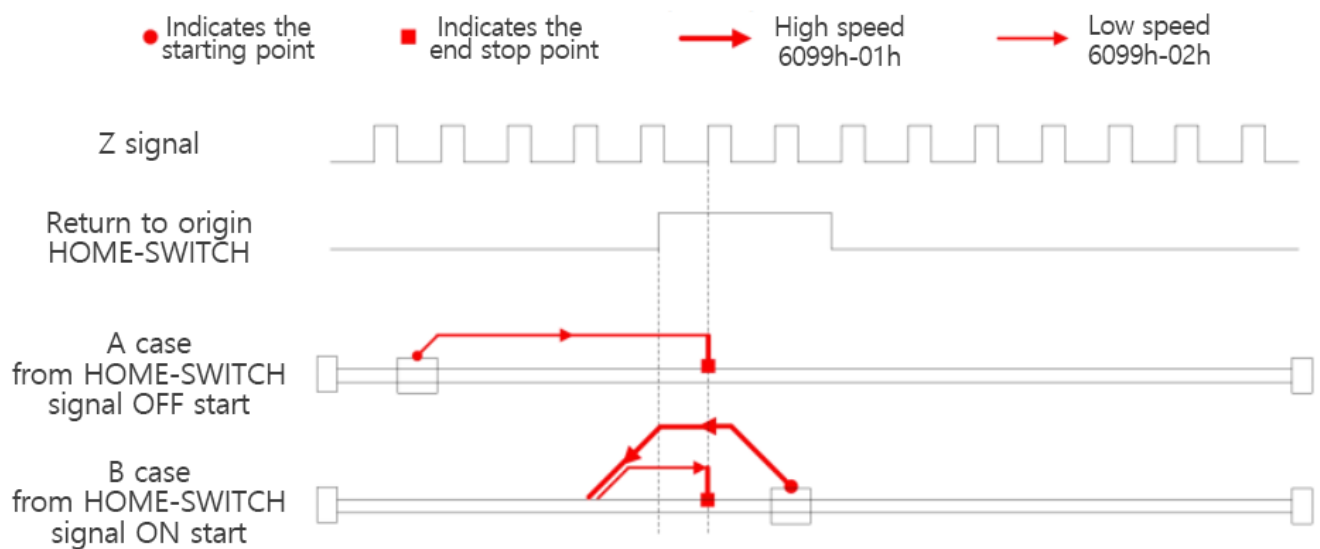

**Method 4 Diagram**

#### Method 5:

If the origin signal is invalid, the motor will move in A negative direction at A high speed at the origin until the origin signal is valid. After the motor slows down and stops, it will move at A low speed at the origin in A positive direction. When the first encoder Z signal after leaving the origin signal switch is valid, the motor will stop moving, as shown in Figure A.

If the motor stops at the origin signal switch position when it starts to move at the origin, it will move forward at the origin low speed and stop when the first Z signal after leaving the origin signal switch is effective, as shown in Figure B.

If the limit signal is effective during the movement, the status word (6041h) bit 13 will be effective, indicating that the origin motion is wrong, and the motor will stop immediately.

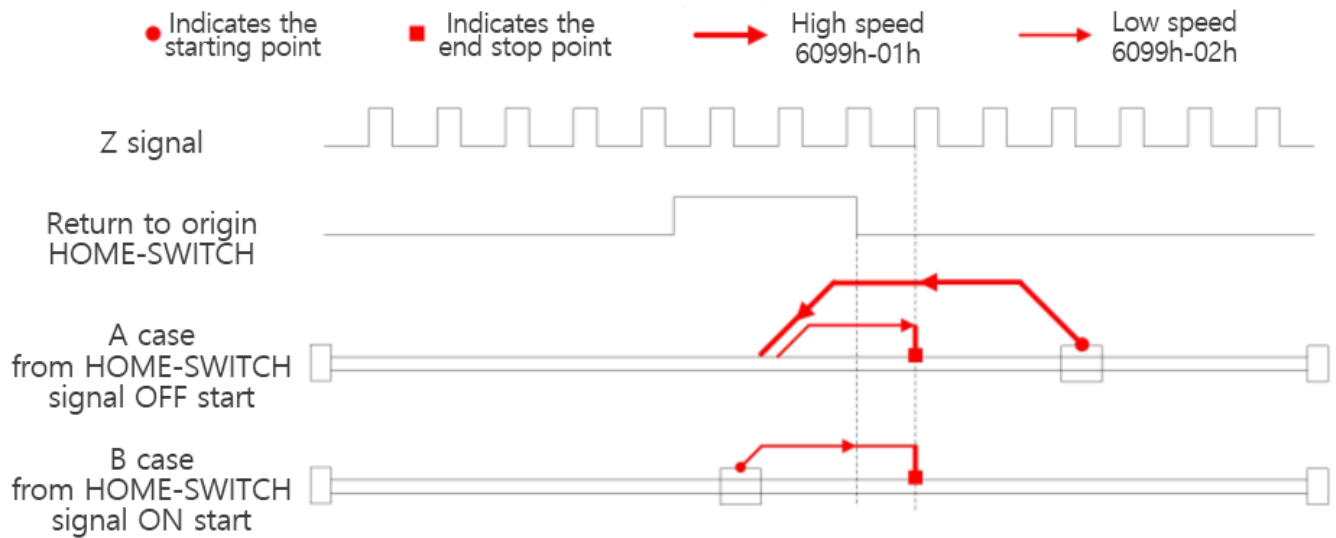

**Method 5 Diagram**

**Methods 6:**

If the origin signal is invalid, the motor will move in the negative direction at low speed at the origin until the first encoder Z signal with valid origin signal stops moving, as shown in Figure A.

If the motor stops at the origin signal switch position when it starts to move at the origin, it will move forward at a high speed at the origin, slow down and stop when it leaves the origin signal switch, and then move in the opposite direction at a low speed at the origin until it stops when the first Z signal with valid origin signal is valid, as shown in Figure B.

If the limit signal is effective during the movement, the status word (6041h) bit 13 will be effective, indicating that the origin motion is wrong, and the motor will stop immediately.

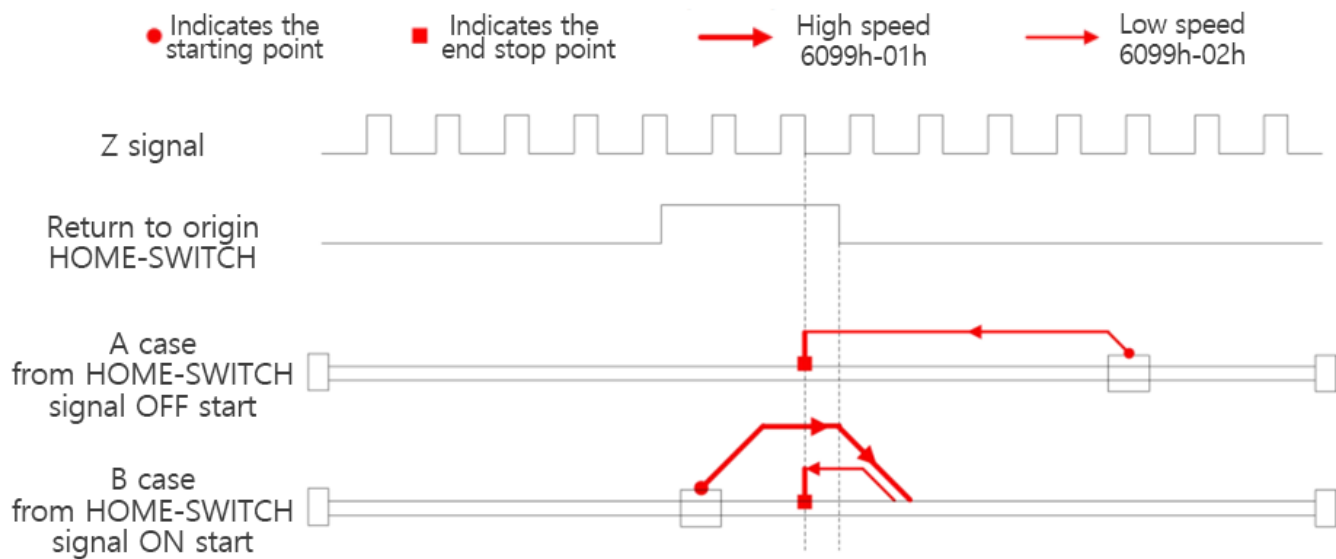

**Method 6 Diagram**

**Methods 7:**

If both the origin signal and the positive limit signal are invalid, the motor will move in the positive direction at high speed at the origin until the origin signal is effective, and then move in the negative direction at low speed at the origin, and stop when the first encoder Z signal leaving the origin signal switch is effective, as shown in FIG. A.

If the positive limit is invalid, the motor will stop at the origin signal switch position when it starts to move at the origin. The motor will move at the origin low speed negatively, and stop when the first Z signal leaving the origin signal switch is effective, as shown in Figure B.

If the origin signal and the signal is invalid is limit, the motor will be positive to origin of high-speed movement, until the limit is effectively stop signal, and then the negative direction to the origin low-speed movement, to continue movement in the origin signal is valid, until leave the origin signal switch Z first encoder signal effectively stop motion, as shown in figure C.

If the negative limit signal is effective during the movement, the status word (6041h) bit 13 will be effective, indicating that the origin motion is wrong, and the motor will stop immediately.

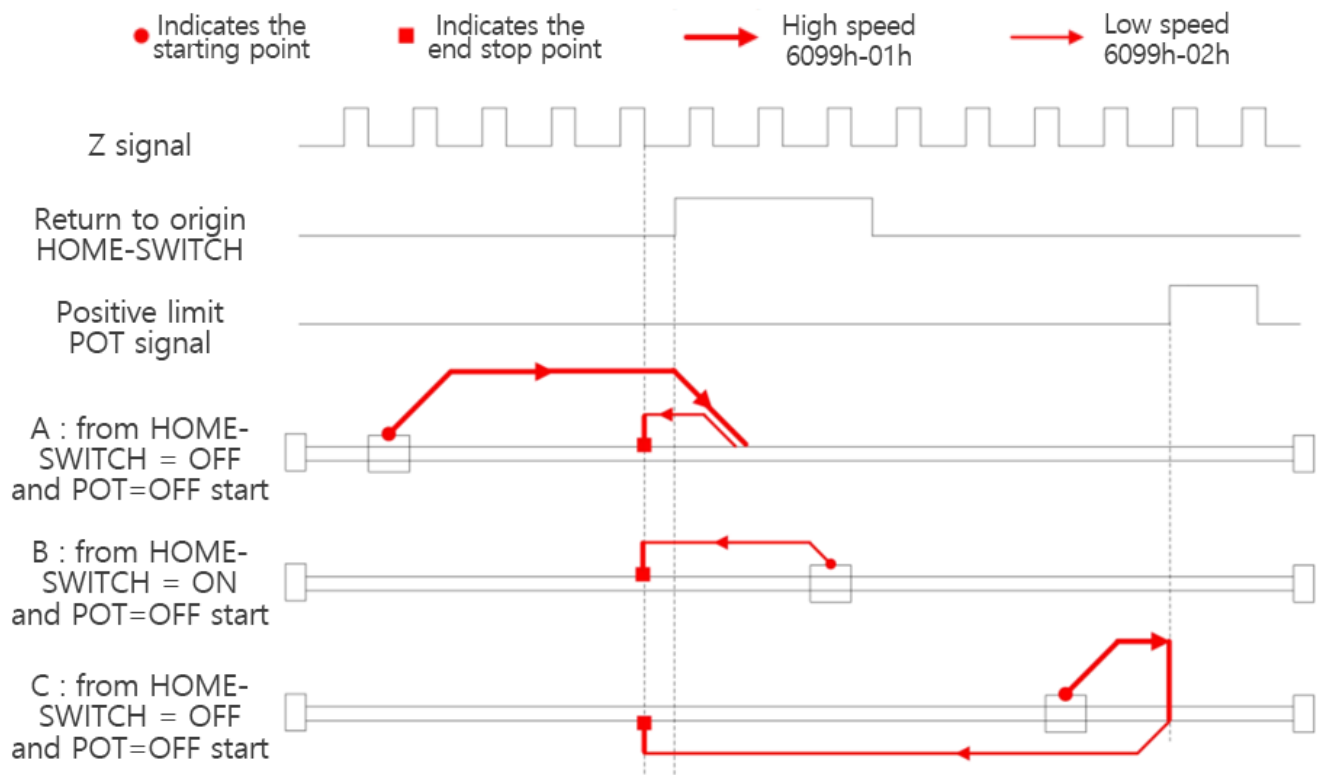

**Method 7 Diagram**

**Methods 8:**

If both the origin signal and the positive limit signal are invalid, the motor will move in the positive direction at low speed at the origin and stop moving when the first encoder Z signal with valid origin signal is valid, as shown in FIG. A.

If the positive limit is invalid, the motor will stop at the origin signal switch position when it starts to move at the origin, and move at a high speed at the origin in a negative direction. After leaving the origin signal switch, the motor will slow down and stop, and then move at a low speed in a positive direction, and stop when the first Z signal after the origin signal is effective, as shown in Figure B.

If the origin signal and the signal is invalid is limit, the motor will be positive in origin of low speed movement, until the limit is effectively stop signal, and then the negative direction to the origin high-speed movement, to continue movement in the origin signal is valid, until after leaving the origin signal switch to slow down to stop, and then to forward to origin of low-speed movement, and then at the origin signal Z effective after the first encoder signal effectively stop motion, as shown in figure C.

If the negative limit signal is effective during the movement, the status word (6041h) bit 13 will be effective, indicating that the origin motion is wrong, and the motor will stop immediately.

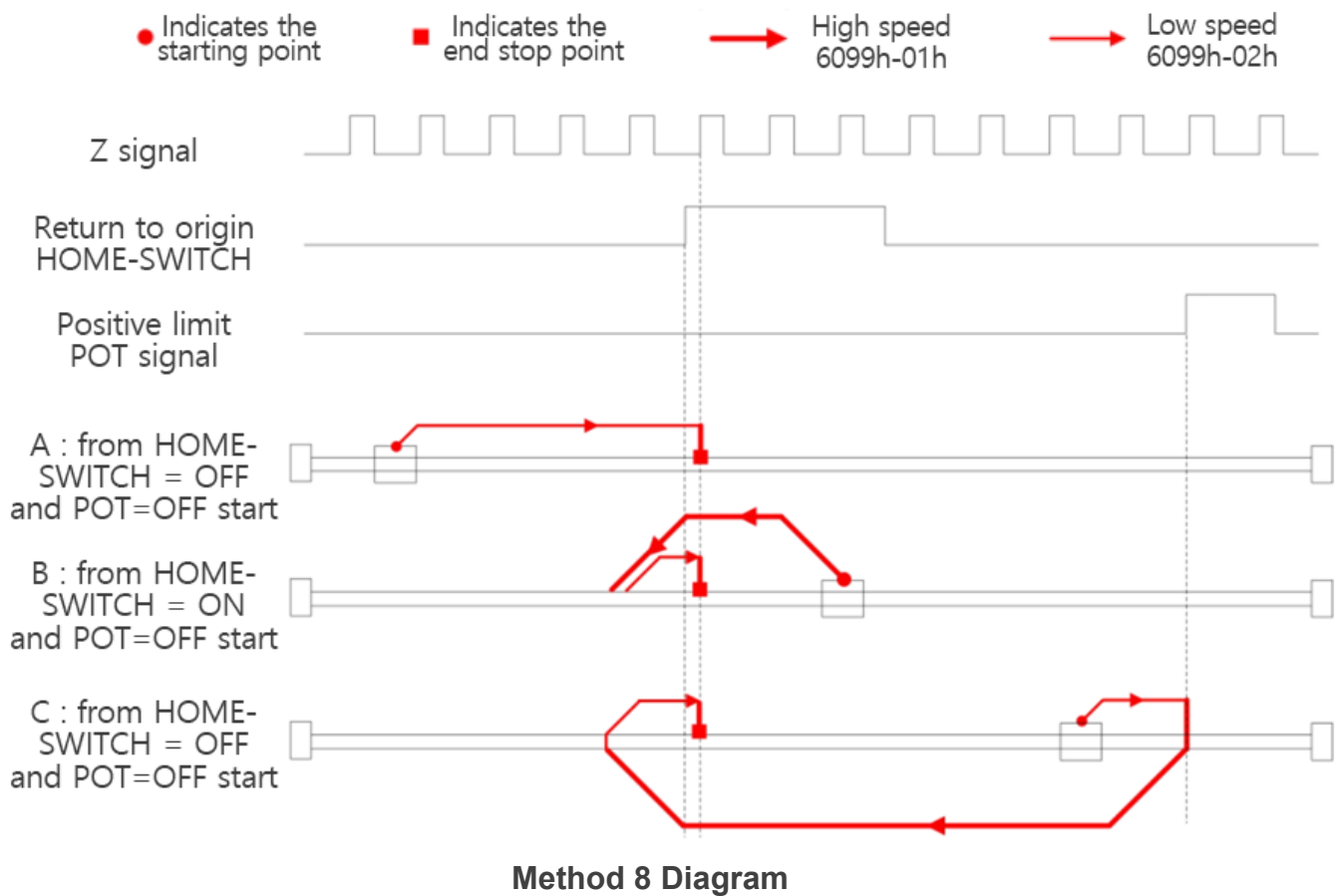

**Methods 9:**

If the origin signal and the signal is invalid is limit, the motor will toward the positive direction

to origin of high-speed movement, the origin signal is valid to continue to exercise, slow stop when leaving the origin signal switch, then turn negative origin in slow motion, until the origin signal Z effective after the first encoder signal effectively stop motion, as shown in figure A.

If the positive limit is invalid, the motor will stop at the origin signal switch position when it starts to move at the origin. The motor will move at a high speed forward at the origin, slow down after leaving the origin signal switch, then move at a low speed at the origin in a negative direction, and stop when the first Z signal after the origin signal is valid, as shown in Figure B.

If both the origin signal and the positive limit signal are invalid, the motor will move at high speed towards the origin until the positive limit signal is effectively stopped, and then move at low speed towards the origin in the negative direction. It will stop moving when the first encoder Z signal after the origin signal is effective, as shown in FIG. C.

If the negative limit signal is effective during the movement, the status word (6041h) bit 13 will be effective, indicating that the origin motion is wrong, and the motor will stop immediately.

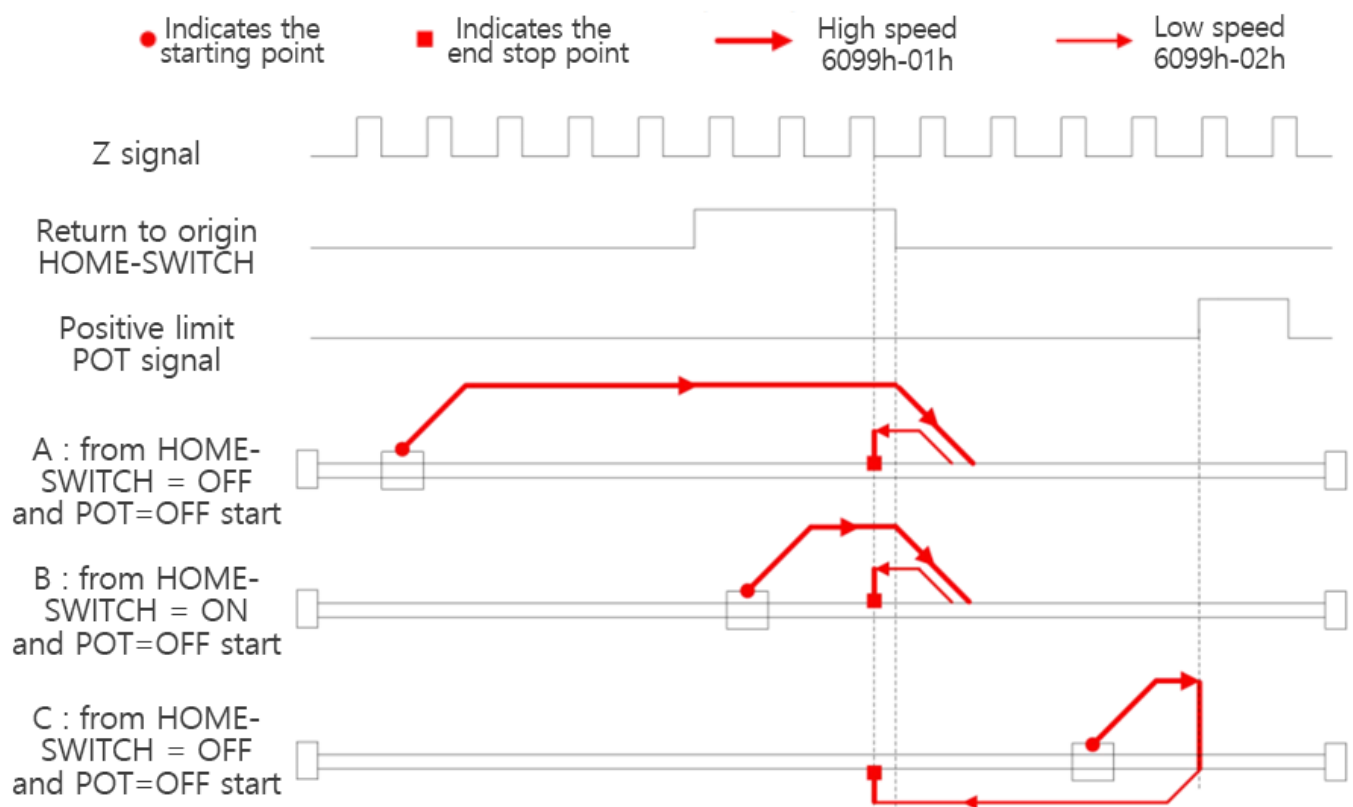

**Method 9 Diagram**

**Methods 10:**

If both the origin signal and the positive limit signal are invalid, the motor will move in the positive direction at the low speed of the origin. When the origin signal is valid, the motor will

continue to move until the first encoder Z signal after the origin signal is invalid stops moving, as shown in Figure A.

If the positive limit is invalid, the motor will stop at the switch position of the origin signal when it starts to move at the origin. The motor will move forward at low speed at the origin and stop when the first Z signal after the origin signal is invalid, as shown in Figure B.

If the origin signal and the signal is invalid is limit, the motor will be positive in origin of low speed movement, until is limit signals effectively after abrupt stop, and then the negative direction to high speed movement, the origin at the origin signal effectively and stop slowing down, and then to forward to origin low-speed movement, until the origin signal is invalid after the first encoder signal Z effective stop motion, as shown in figure C.

If the negative limit signal is effective during the movement, the status word (6041h) bit 13 will be effective, indicating that the origin motion is wrong, and the motor will stop immediately.

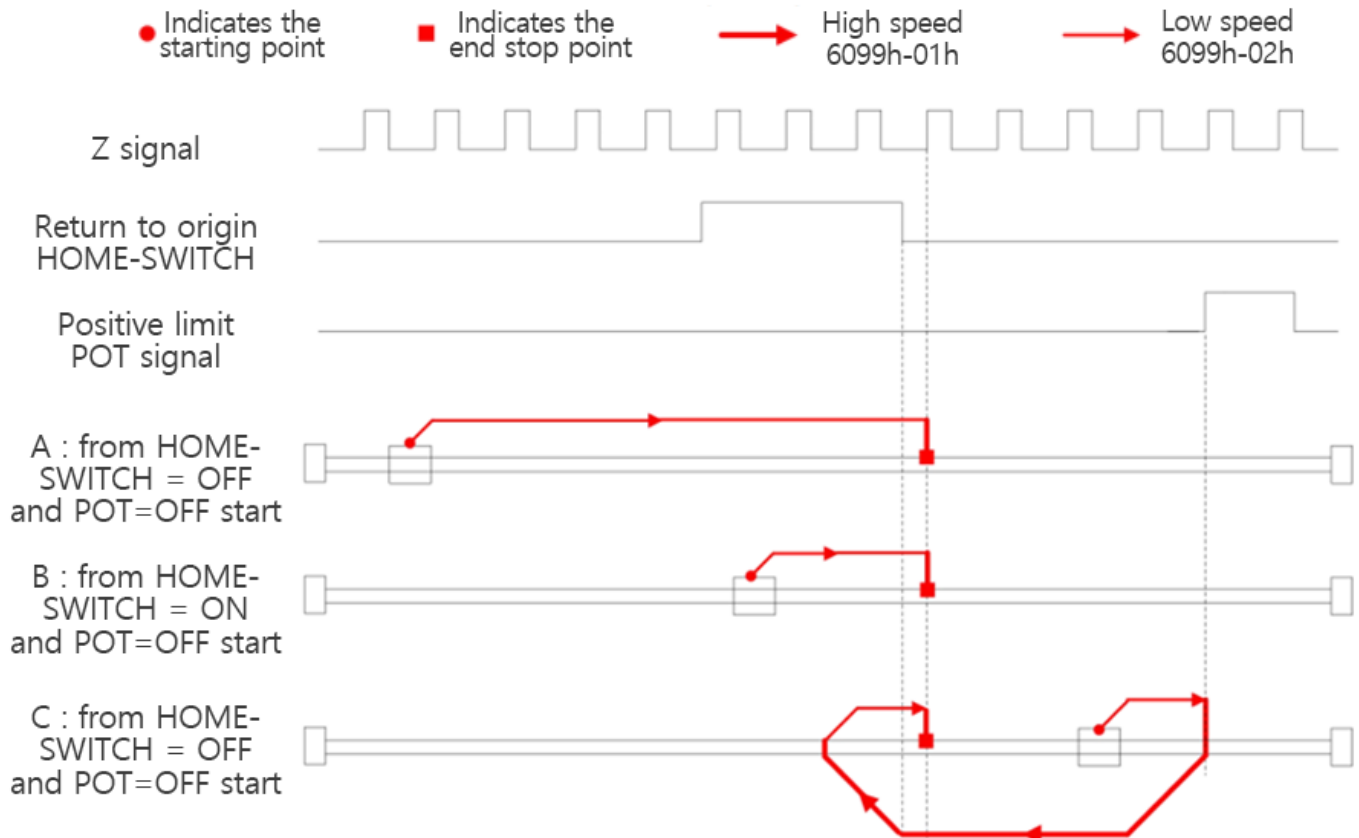

**Method 10 Diagram**

**Methods 11**

If both the origin signal and the negative limit signal are invalid, the motor will move at A high speed in the negative direction at the origin until the origin signal is effective, and then move at A low speed at the origin in the positive direction, and stop when the first encoder Z signal

leaving the origin signal switch is effective, as shown in Figure A.

If the negative limit is invalid, the motor will stop at the origin signal switch position when it starts to move at the origin. The motor will move forward at the origin low speed and stop when the first Z signal leaving the origin signal switch is effective, as shown in Figure B.

If the origin signal and negative limit signal is invalid, the motor will toward the negative to the origin high-speed movement, until negative limit effectively stop signal, and then the positive direction to the origin, low-speed movement, to continue movement in the origin signal is valid, until leave the origin signal switch Z first encoder signal effectively stop motion, as shown in figure C.

If the positive limit signal is effective during the movement, the status word (6041h) bit 13 will be effective, indicating that the origin motion is wrong, and the motor will stop immediately.

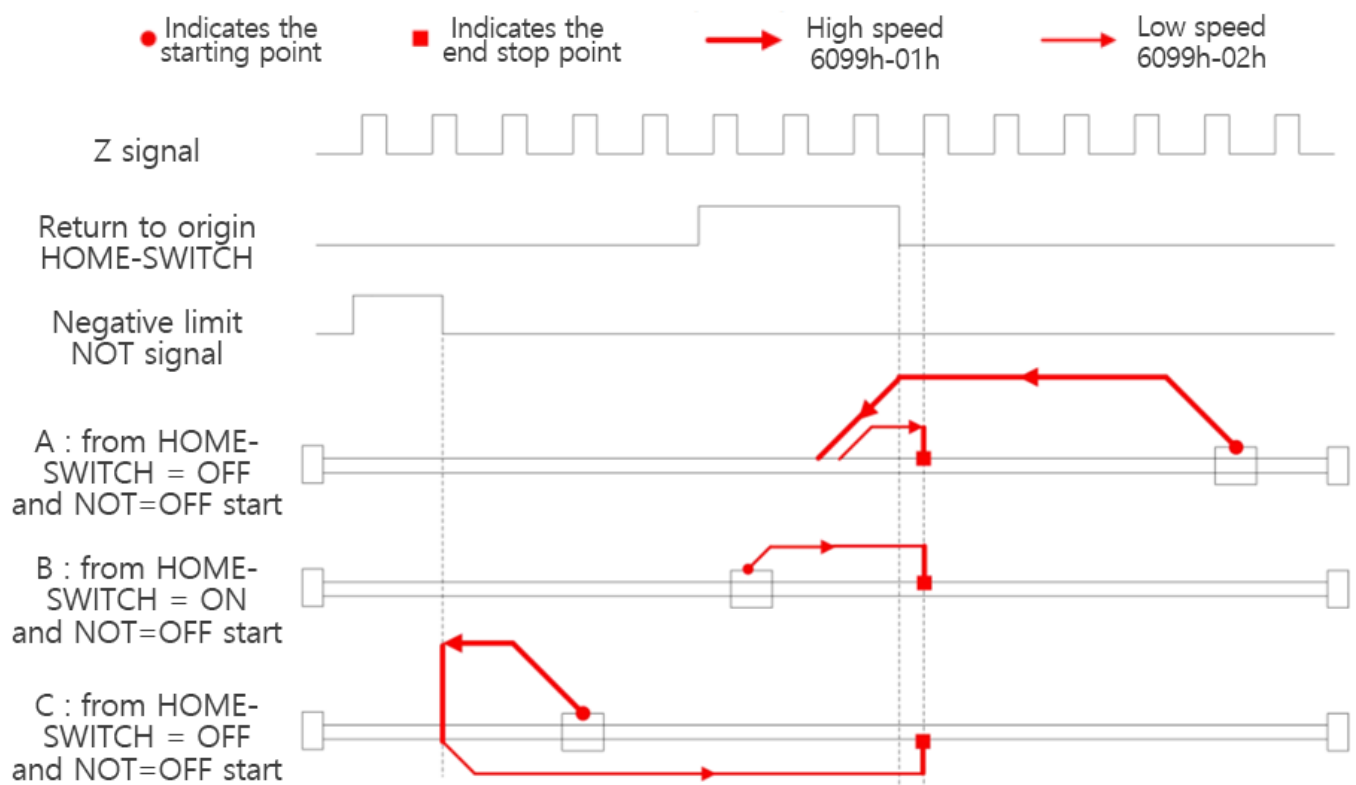

**Method 11 Diagram**

### Methods 12:

If both the origin signal and the negative limit signal are invalid, the motor will move in the negative direction at low speed at the origin, and stop moving when the first encoder Z signal with valid origin signal is valid, as shown in FIG. A.



If the negative limit is invalid, the motor will stop at the origin signal switch position when it starts to move at the origin and move at a high speed forward at the origin. After leaving the origin signal switch, the motor will slow down and stop, then move at a low speed at the origin negatively, and stop when the first Z signal after the origin signal is valid, as shown in Figure B.

If origin signals and negative limit are invalid, the motor will be toward the negative origin in slow motion, until negative limit effectively stop signal, and then the positive direction to the origin of high-speed movement, to continue movement in the origin signal is valid, until after leaving the origin signal switch to slow down to stop, then turn negative origin in slow motion, and then at the origin signal Z effective after the first encoder signal effectively stop motion, as shown in figure C.

If the positive limit signal is effective during the movement, the status word (6041h) bit 13 will be effective, indicating that the origin motion is wrong, and the motor will stop immediately.

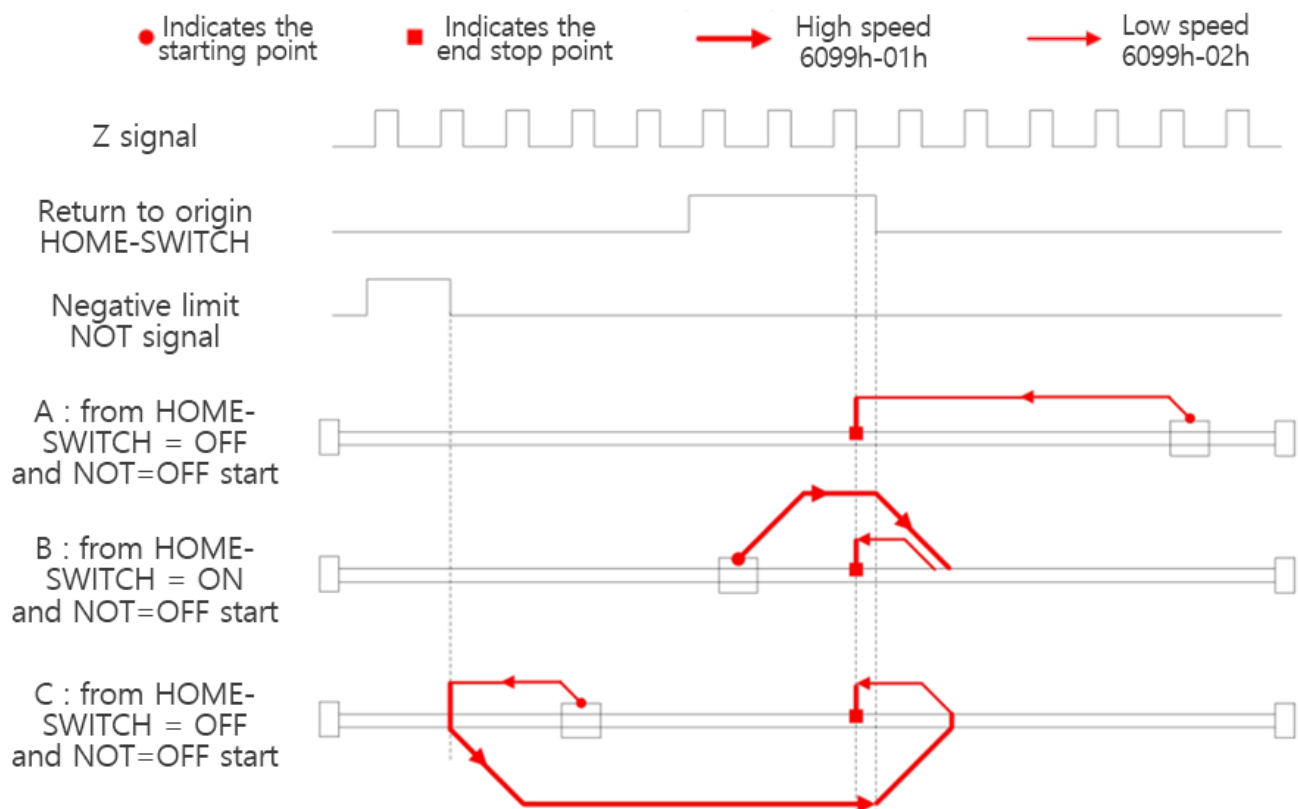

**Method 12 Diagram**

### Methods 13:

If the origin signal and negative limit signal is invalid, the motor will be toward the negative direction of the origin in the high-speed movement, the origin signal is valid to continue movement, slowing down to stop when leaving the origin signal switch, and then to forward to origin low-speed movement, until the origin signal Z effective after the first encoder signal

effectively stop moving, as shown in figure A.

If the negative limit is invalid, the motor will stop at the origin signal switch position when it starts to move at the origin and will move at a high speed at the origin in a negative direction. After leaving the origin signal switch, the motor will slow down and stop, and then move at a low speed in a positive direction. It will stop when the first Z signal after the origin signal is effective, as shown in Figure B.

If both the origin signal and the negative limit signal are invalid, the motor will move at a high speed towards the negative limit signal until the negative limit signal is effectively stopped, then move at a low speed towards the positive direction, and stop when the first encoder Z signal after the origin signal is effective, as shown in FIG. C.

If the negative limit signal is effective during the movement, the status word (6041h) bit 13 will be effective, indicating that the origin motion is wrong, and the motor will stop immediately.

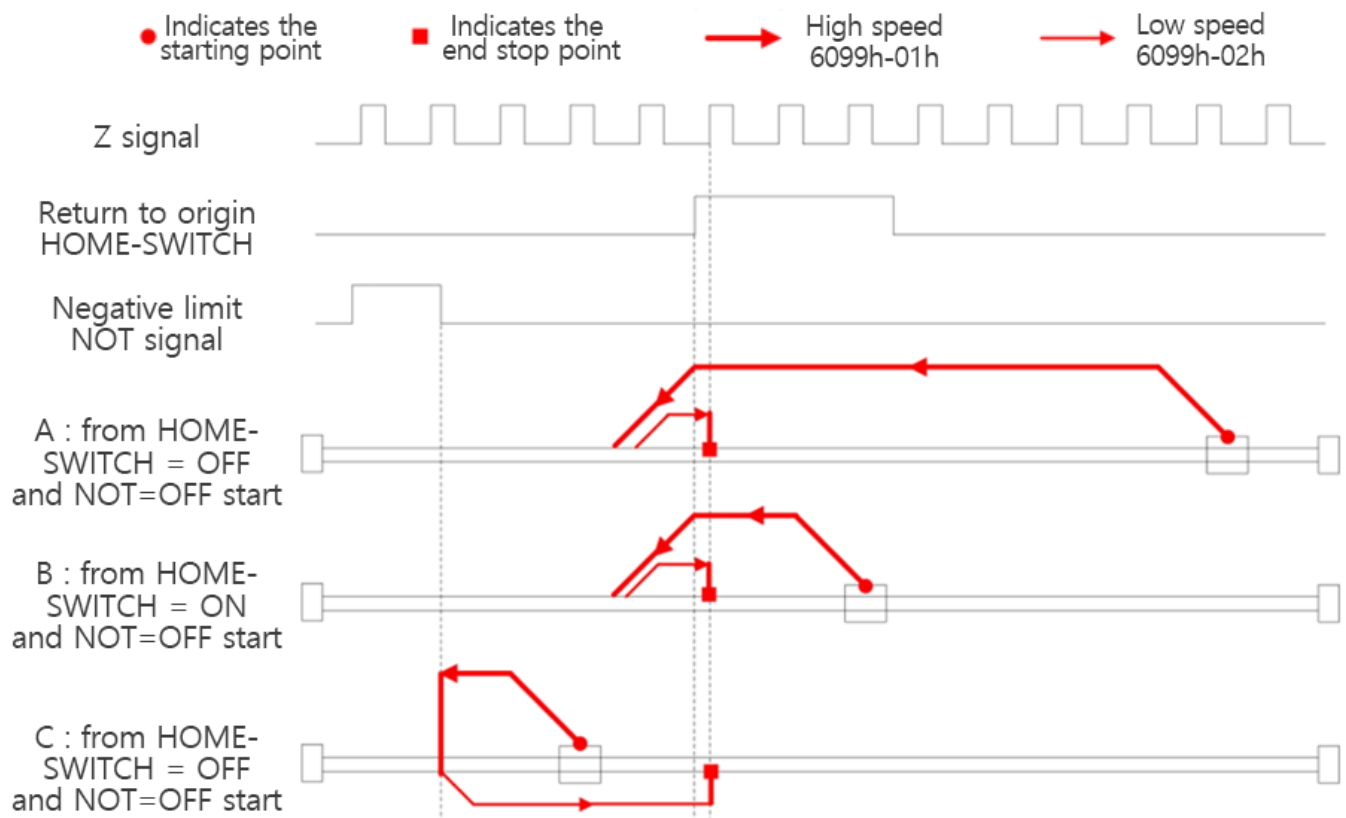

**Method 13 Diagram**

#### Methods 14:

If both the origin signal and the negative limit signal are invalid, the motor will move in the negative direction at the low speed of the origin. When the origin signal is valid, the motor will continue to move until the first encoder Z signal after the origin signal is invalid stops moving, as shown in Figure A.

If the negative limit is invalid, the motor will stop at the switch position of the origin signal when

it starts to move at the origin. The motor will move at the low speed at the origin negatively, and stop when the first Z signal after the origin signal is invalid, as shown in Figure B.

If the origin signal and negative limit signal is invalid, the motor will be toward the negative origin in slow motion, until the stop after negative limit signals effectively, high speed movement, and then the positive direction to the origin at the origin signal effectively and stop slowing down, and then to negative origin in slow motion, Z until the origin signal is invalid after the first encoder signal effectively stop motion, as shown in figure C.

If the negative limit signal is effective during the movement, the status word (6041h) bit 13 will be effective, indicating that the origin motion is wrong, and the motor will stop immediately.

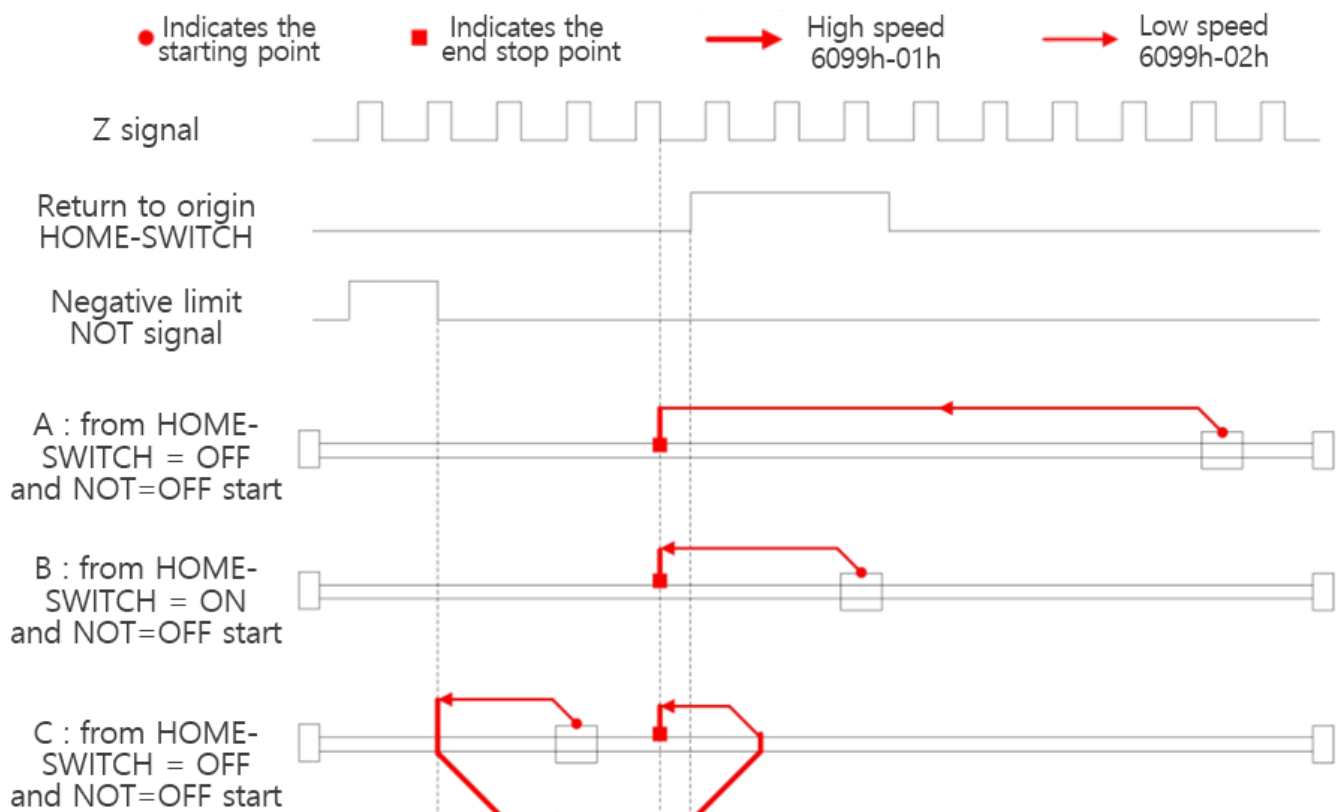

**Method 14 Diagram**

**Methods 17:**

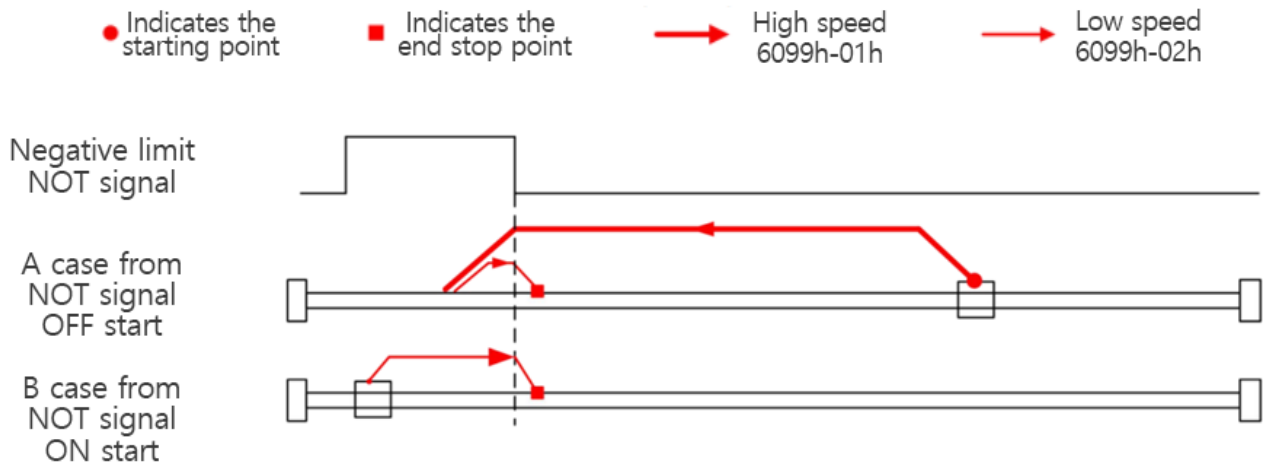

**Method 17 Diagram**

**Method 18:**

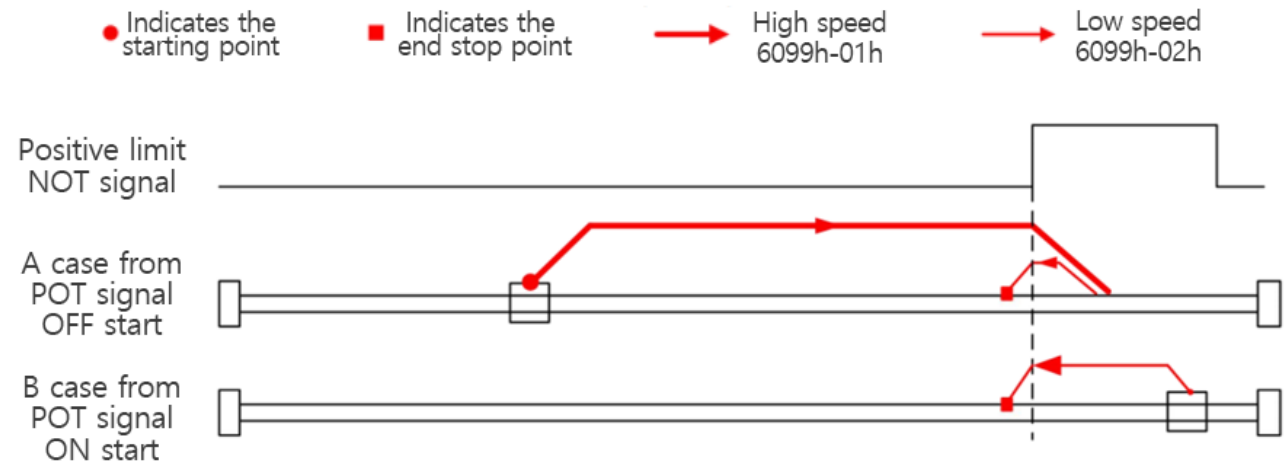

**Method 18 Diagram**

**Method 19:**

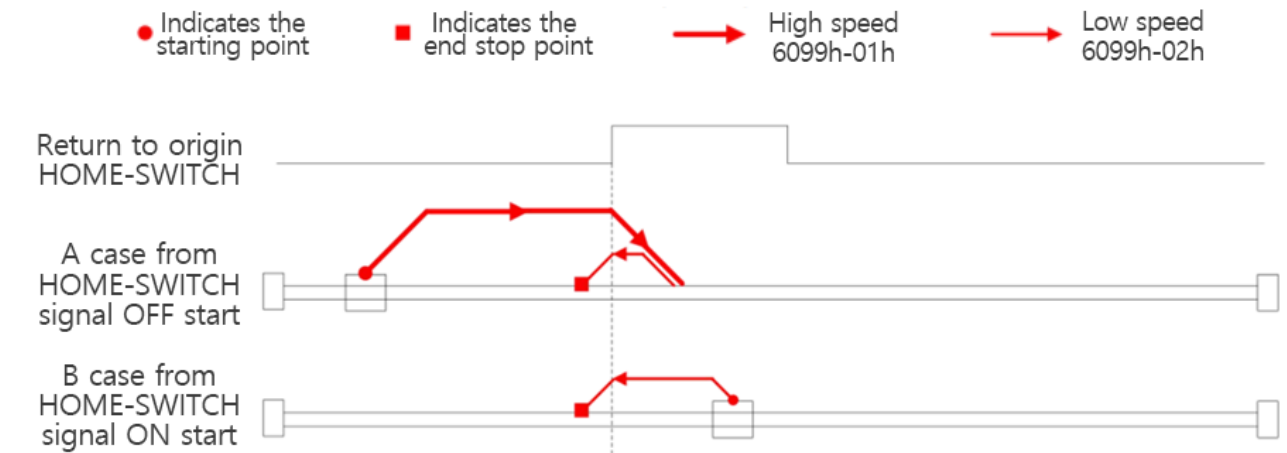

**Method 19 Diagram**

**Method 20:**

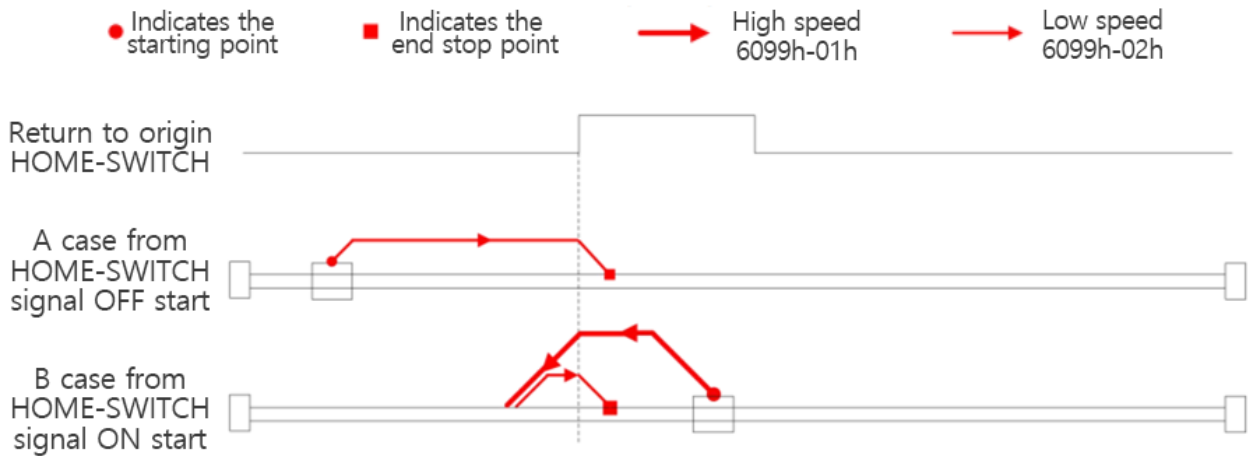

**Method 20 Diagram**

**Method 21:**

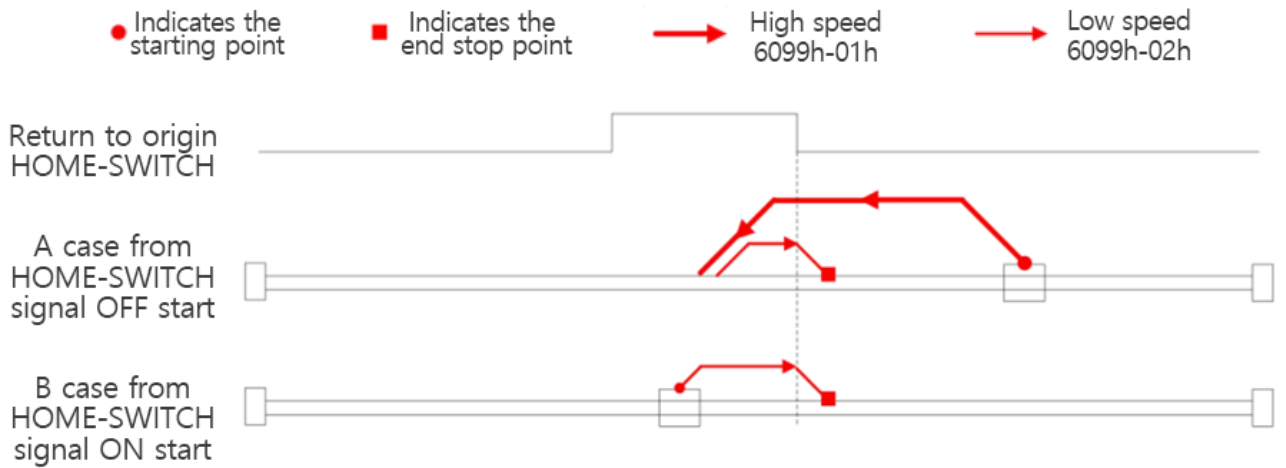

**Method 21 Diagram**

**Method 22:**

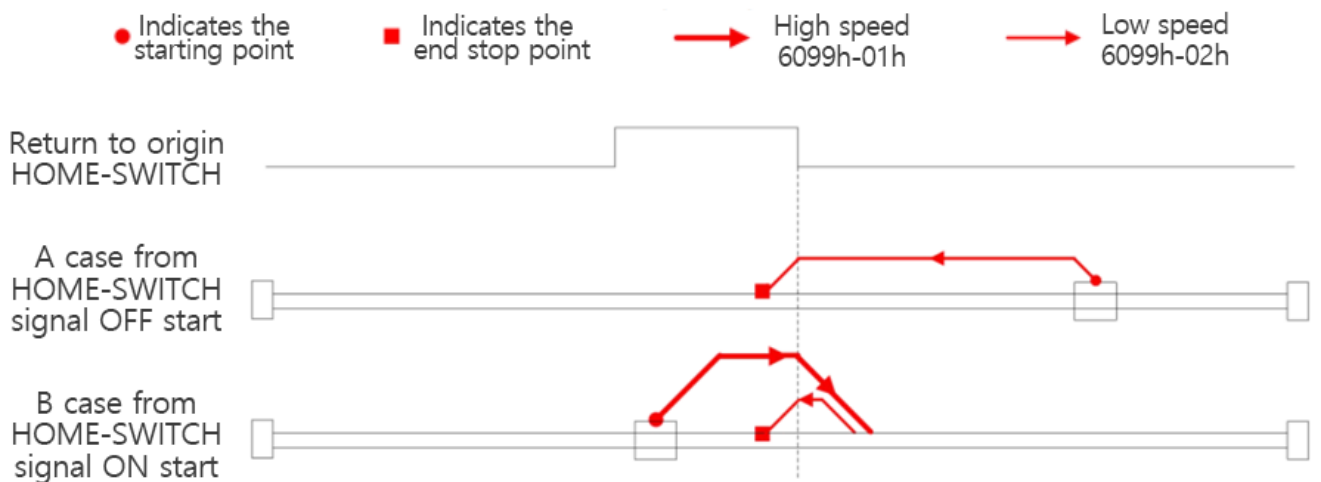

**Method 22 Diagram**

**Method 23:**

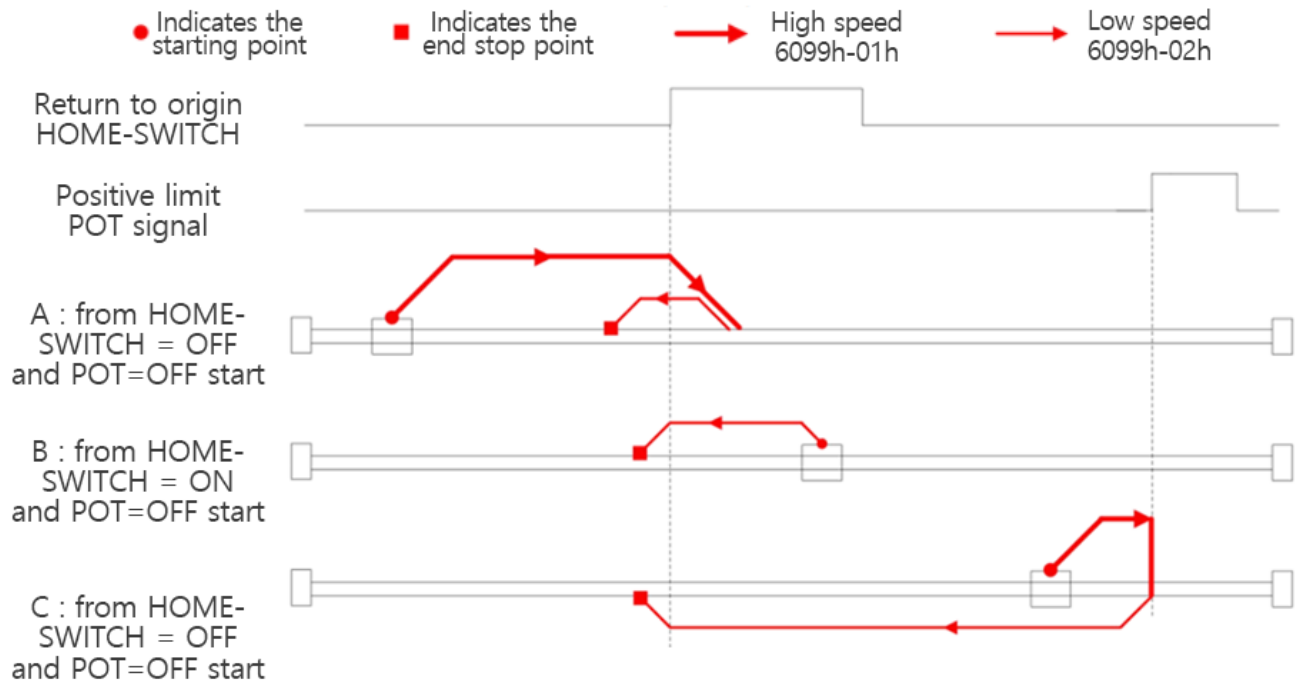

**Method 23 Diagram**

**Method 24:**

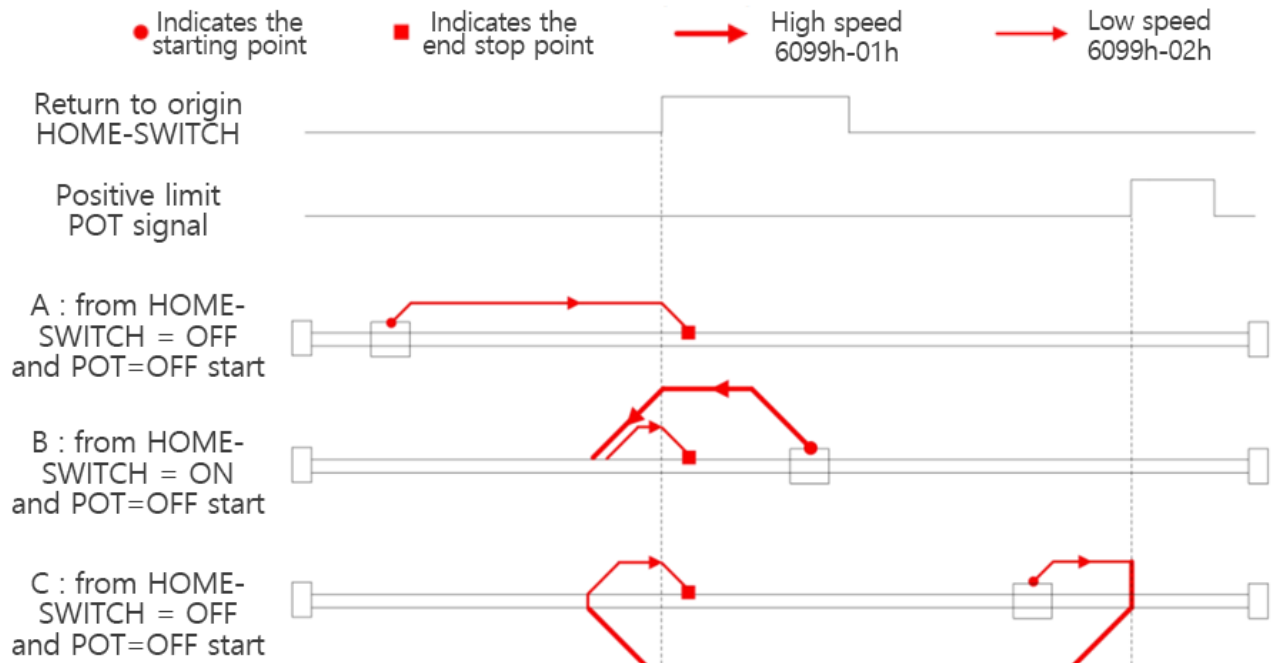

**Method 24 Diagram**

**Method 25:**

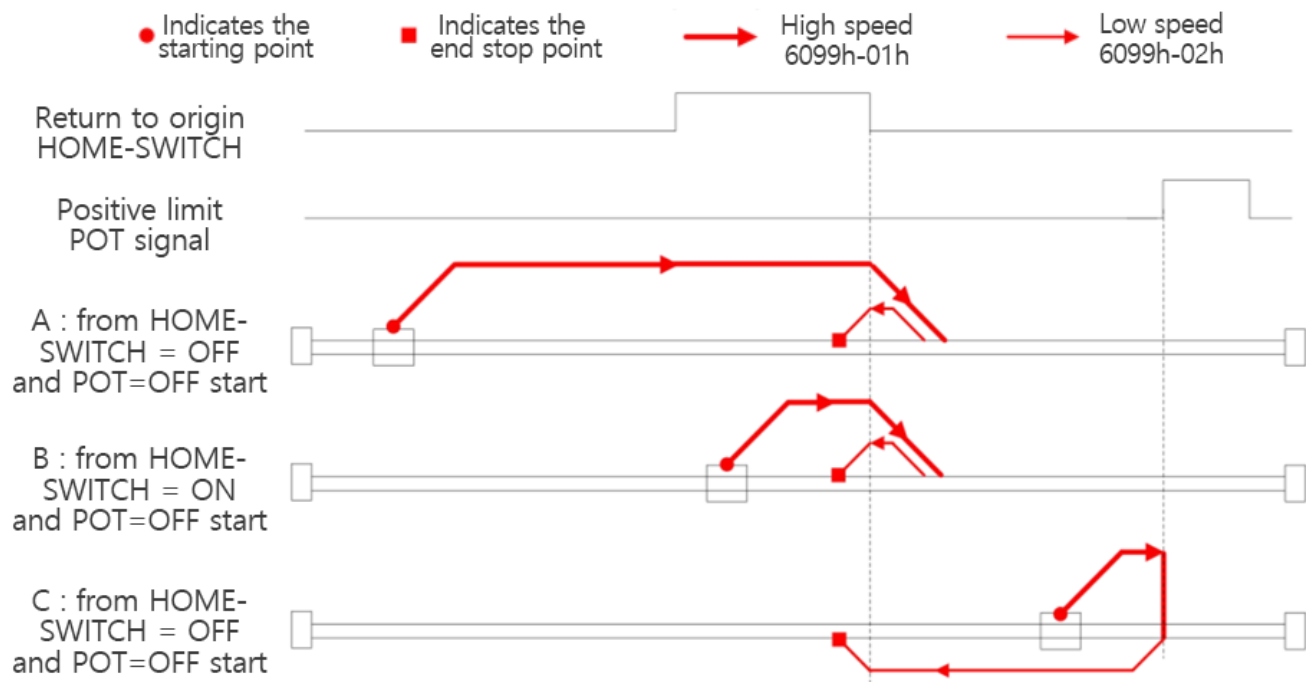

**Method 25 Diagram**

**Method 26:**

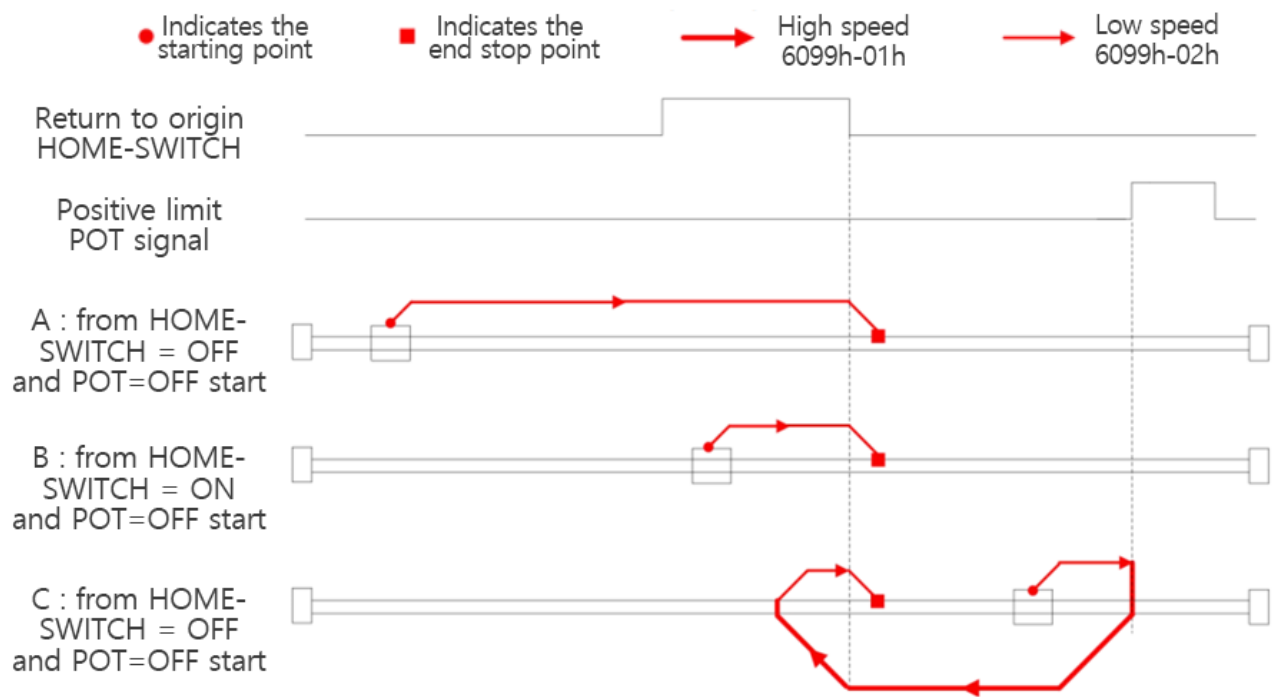

**Method 26 Diagram**

**Method 27:**

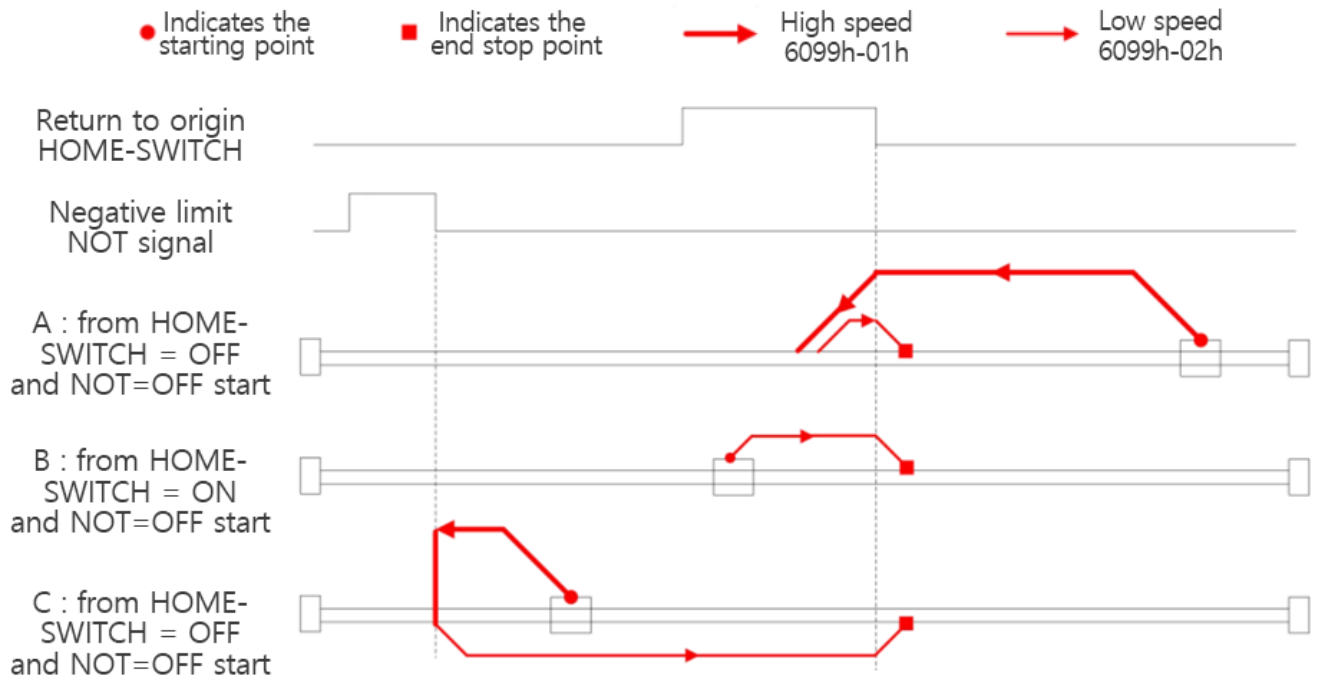

**Method 27 Diagram**

**Method 28:**

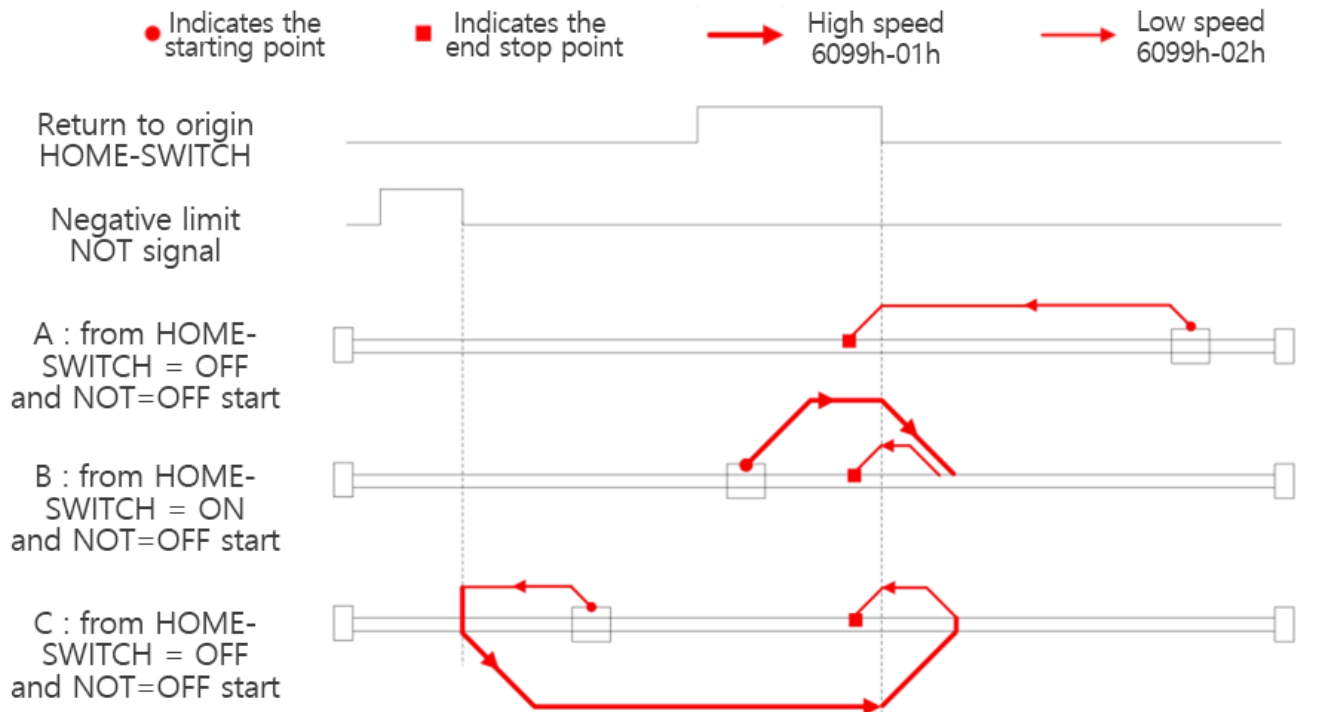

**Method 28 Diagram**



**Method 29:**

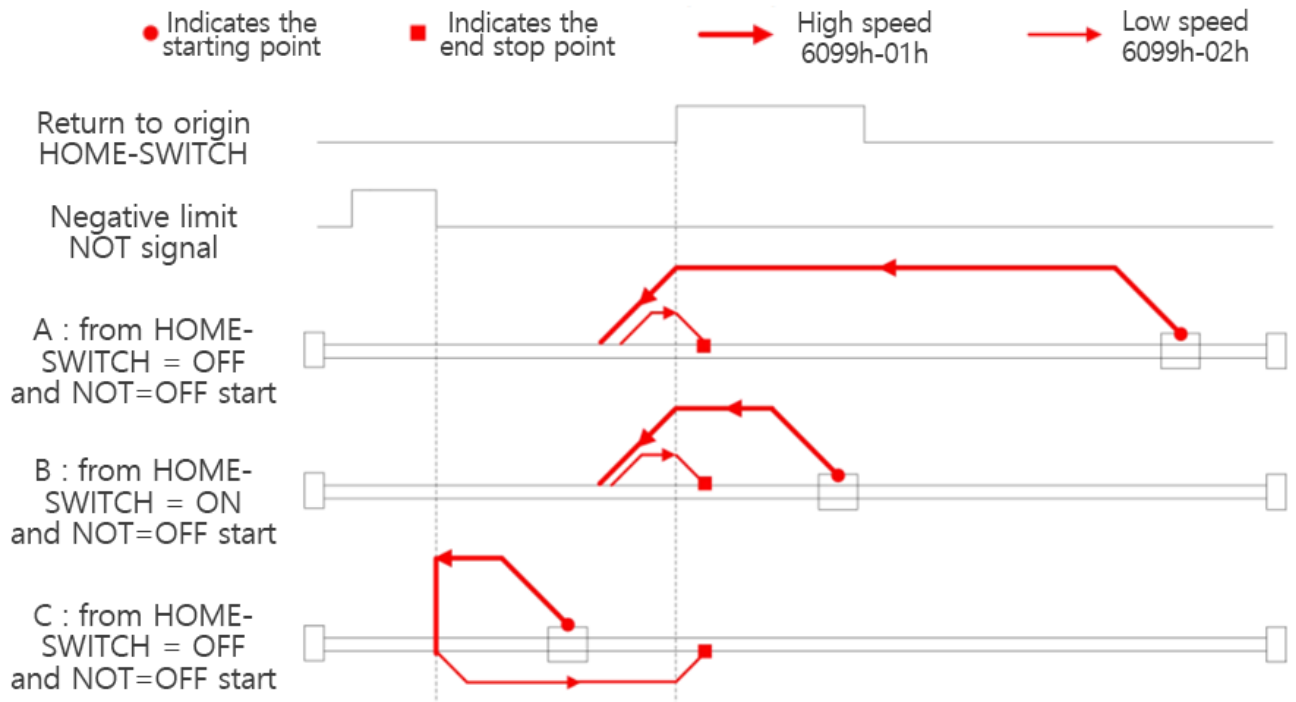

**Method 29 Diagram**

**Method 30:**

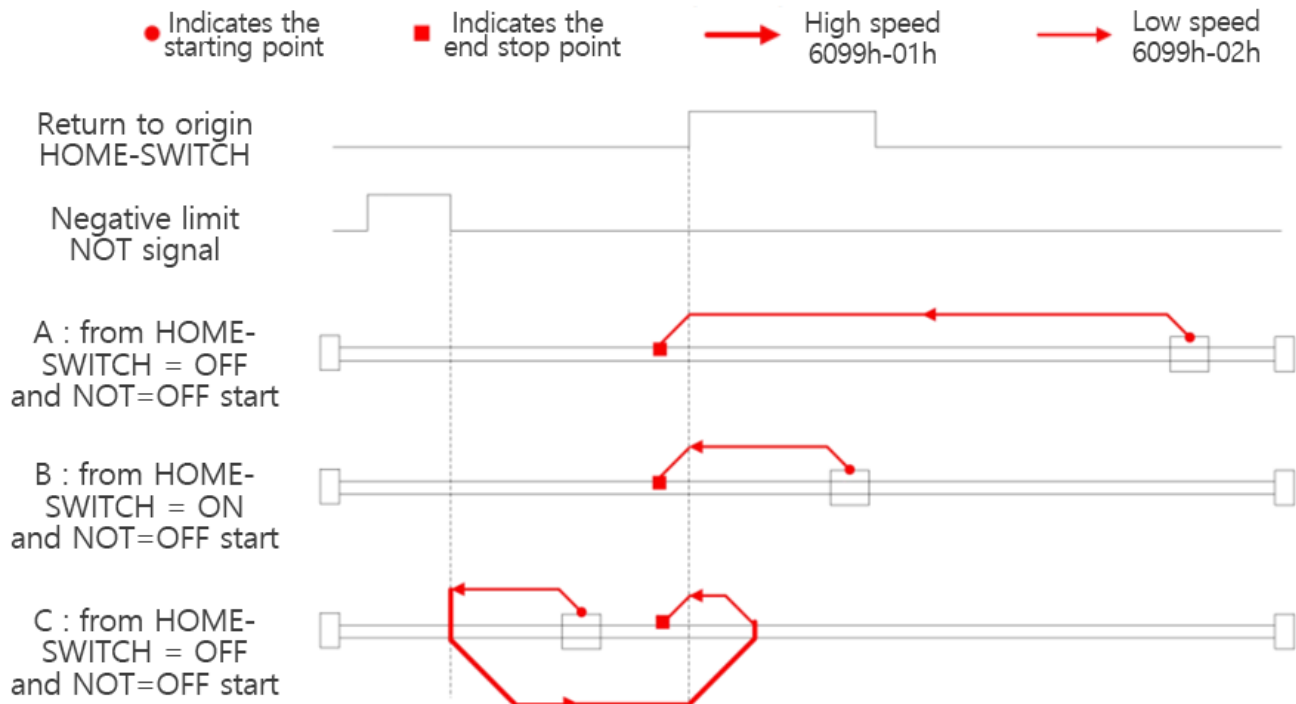

**Method 30 Diagram**

**Method 33**

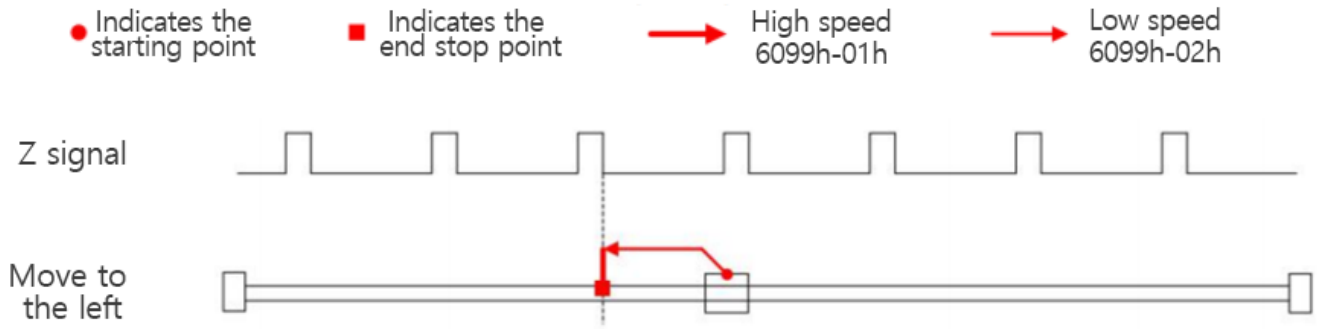

**Method 33 Diagram**

**Method 34:**

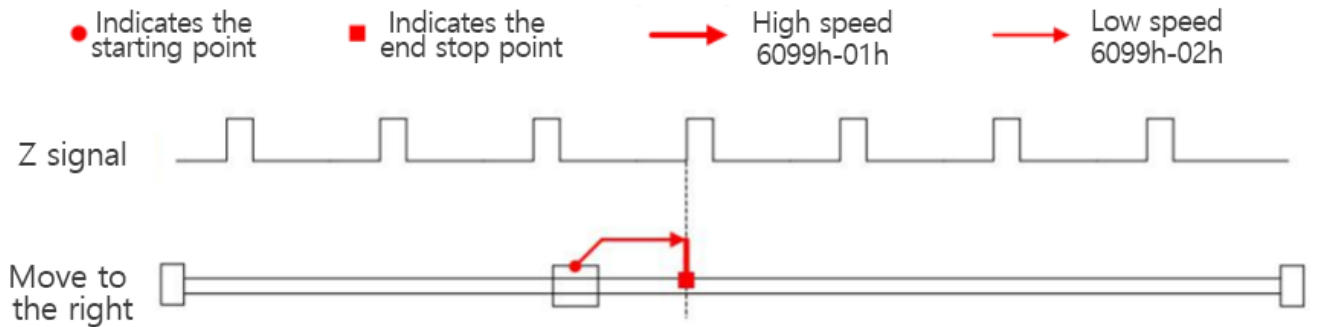

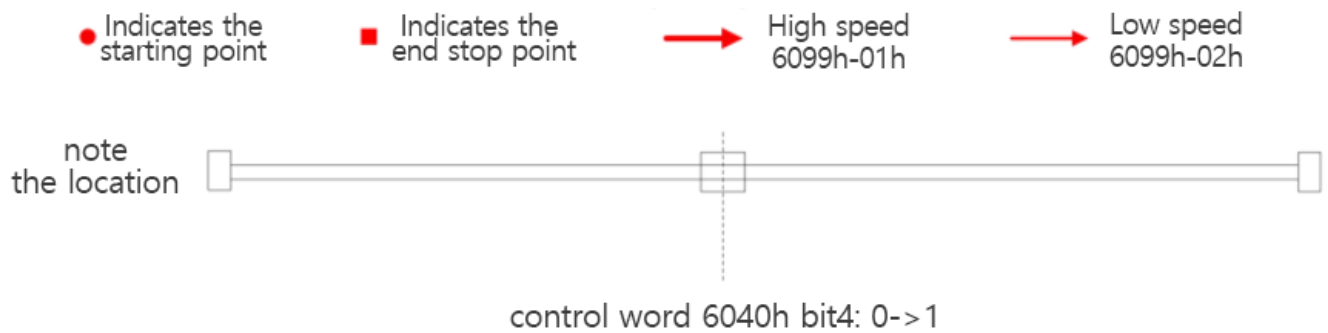

**Method 34 Diagram**

**Method 35:**



 +86-0519-8517 7825

 +86-0519-8517 7807

 No. 2850 Luheng Road, Changzhou Economic  
Development Zone, Jiangsu Province, China

 [www.dingsmotion.com](http://www.dingsmotion.com)

## International Customer

Person in Charge :

*Daniel Jang*

[daniel@dingsmotion.com](mailto:daniel@dingsmotion.com)

No. 2850 Luheng Road, Changzhou  
Economic Development Zone,  
Jiangsu Province, China

+86-519-85177825, 85177826

## North America Customer

Person in Charge :

*Nicolas Ha*

[sales@dingsmotionusa.com](mailto:sales@dingsmotionusa.com)

335 Cochrane Circle Morgan Hill,  
CA 95037

+1-408-612-4970

## China Customer

Person in Charge :

*Sweet Shi*

[info@dingsmotion.com](mailto:info@dingsmotion.com)

No. 2850 Luheng Road, Changzhou  
Economic Development Zone,  
Jiangsu Province, China

+86-519-85177825, 85177826