

DINGS'
Precision Motion Specialist

GRIPPER PRODUCT CATALOG



Based on our own design and development of through motor foundation, the stroke of 6mm and 12mm Gripper can be selected.

The structure is compact and simple, which can replace the pneumatic clamping claw, reduce the operation noise, and effectively improve the accuracy.

High resolution of encoder based closed loop torque control Motion Controller is optional.



GRIPPER

CONTENTS

Part number construction
Gripper 20mm (Stroke Length 6mm)
Gripper 28mm (Stroke Length 6mm / 12mm)
35mm 3-Finger Gripper
42mm 3-Finger Gripper

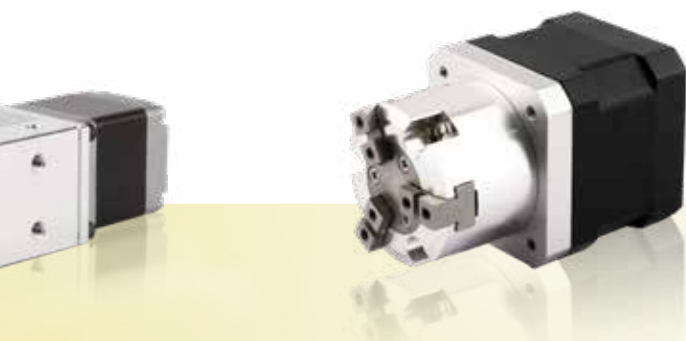

Part Number Construction

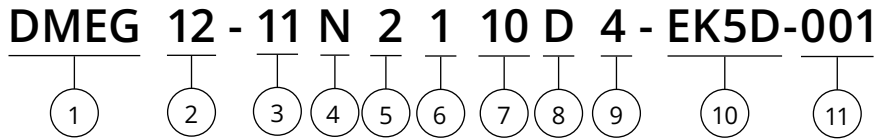

① Product Name
Electric Gripper

② Stroke (mm)
12 = 12 mm

③ Motor Size

Motor Size (mm)	20	28	35	42
Motor Size (NEMA)	8	11	14	17

④ Motor Type
N = Non-Captive type

⑤ Motor Step Angle
2 = 2 Phase with 1.8°

⑥ Motor Length
1 = Single stack
2 = Double stack

⑦ Rated Current / Phase
XX = X.X (A) / Phase

⑦ Lead Screw Code

Please refer to lead screw code selection table

⑧ Number of Lead Wires
4 = 4 Flying leads
6 = 6 Flying leads

⑨ Option
EKX = Encoder [X = Encoder Resolution]
ER = Encoder Ready

⑩ Customer Sequence Number

Example

Part Number	DMEG12-11N2110D4-EK5D-001
Description	Electric Gripper 12mm Stroke NEMA 11 Non-Captive Linear Actuator 2 Phase / 1.8° Stepper Single Stack 1.0A / Phase D Lead (0.05" or 1.27mm) 4 Flying Wires EK5 Encoder with differential output 1,000 lines Serial Number 001

20mm Gripper (6mm Stroke)

Motor Characteristics

Motor	Voltage (V)	Current (A _{RMS})	Resistance (Ω)	Inductance (mH)	Lead wire No.	Motor length (mm)
8N2105	2.5	0.5	5.1	1.5	4	27.2
8N2205	4.4	0.5	8.8	2.7	4	38.1

Available Lead Screw and Travel per Step

Screw Dia. (inch)	Screw Dia. (mm)	Lead (inch)	Lead (mm)	Lead Code	Travel Per Step @1.8° (mm)*
0.138	3.24	0.0394	1	AB	0.005
0.138	3.5	0.0787	2	G	0.01
0.138	3.5	0.1575	4	M	0.02

Gripping Force Recommendation

Motor Size	Body Length (mm)	Part Code	Stroke	Screw Code	Lead (mm)	Max. Gripping Force (N)	Recommended Gripping Force (N)
20mm	27.2	8N2105	6mm	AB	1	25	13
				G	2	21	11
				M	4	11	6
	38.1	8N2205	6mm	AB	1	50	25
				G	2	36	18
				M	4	32	16

Dimensional Drawings

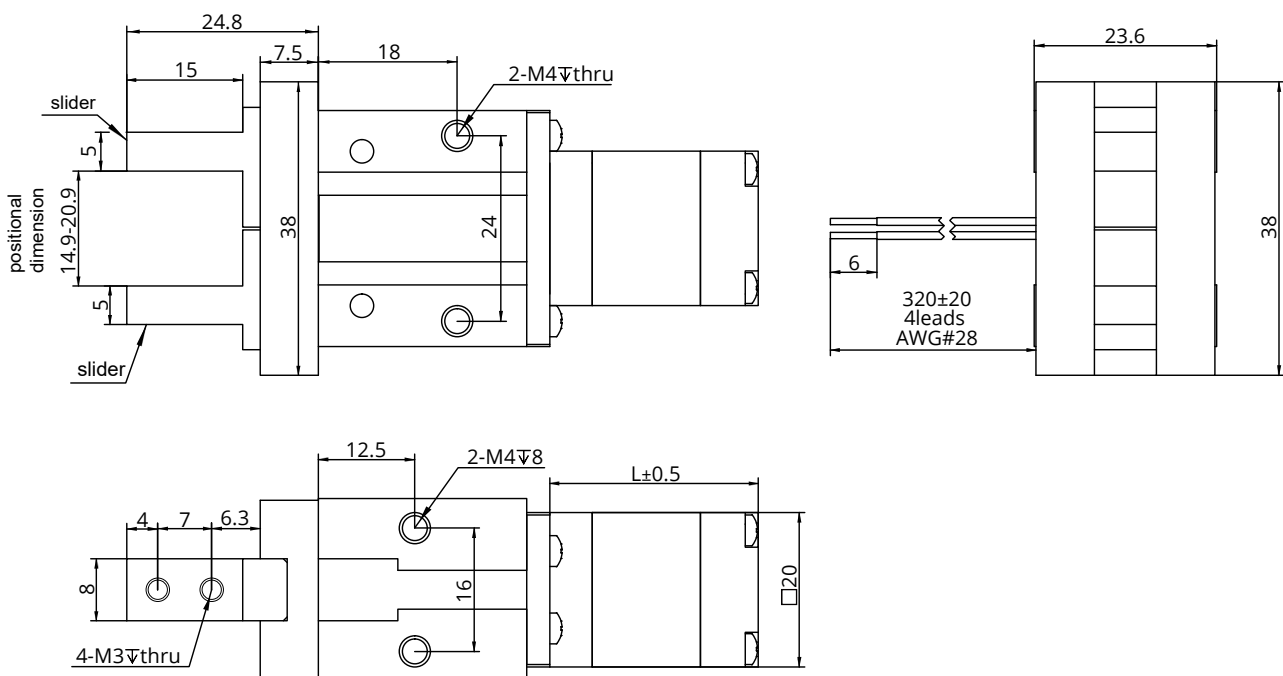

Note : All drawings are 1st Angle Projection - ISO Compliant (3D models available)

28mm Gripper (6 / 12mm Stroke)

Motor Characteristics

Motor	Voltage (V)	Current (A _{RMS})	Resistance (Ω)	Inductance (mH)	Lead wire No.	Motor length (mm)
11N2105	4.5	0.5	9.1	6	4	33.5
11N2110	2.2	1	2.1	1.5	4	33.5
11N2210	4.1	1	4.1	4	4	45
11N2216	2.4	1.6	1.5	1.3	4	45

Available Lead Screw and Travel per Step

Screw Dia. (inch)	Screw Dia. (mm)	Lead (inch)	Lead (mm)	Lead Code	Travel Per Step @1.8° (mm)*
0.188	4.77	0.025	0.635	A	0.003175
0.188	4.77	0.05	1.27	D	0.00635
0.188	4.77	0.1	2.54	K	0.0127
0.188	4.77	0.2	5.08	R	0.0254

Gripping Force Recommendation

Motor Size	Body Length (mm)	Part Code	Stroke	Screw Code	Lead (mm)	Max. Gripping Force (N)	Recommended Gripping Force (N)
28mm	33.5	11N2105 / 2110	6 / 12 mm	A	0.635	110	55
				D	1.27	84	42
				K	2.54	56	28
				R	5.08	36	18
	45	11N2210 / 2216	6 / 12 mm	A	0.635	140	70
				D	1.27	120	60
				K	2.54	100	50
				R	5.08	60	30

For stroke customization, please contact DINGS' or local representative.

28mm Gripper (6 / 12 mm Stroke)

Dimensional Drawings

6mm Stroke

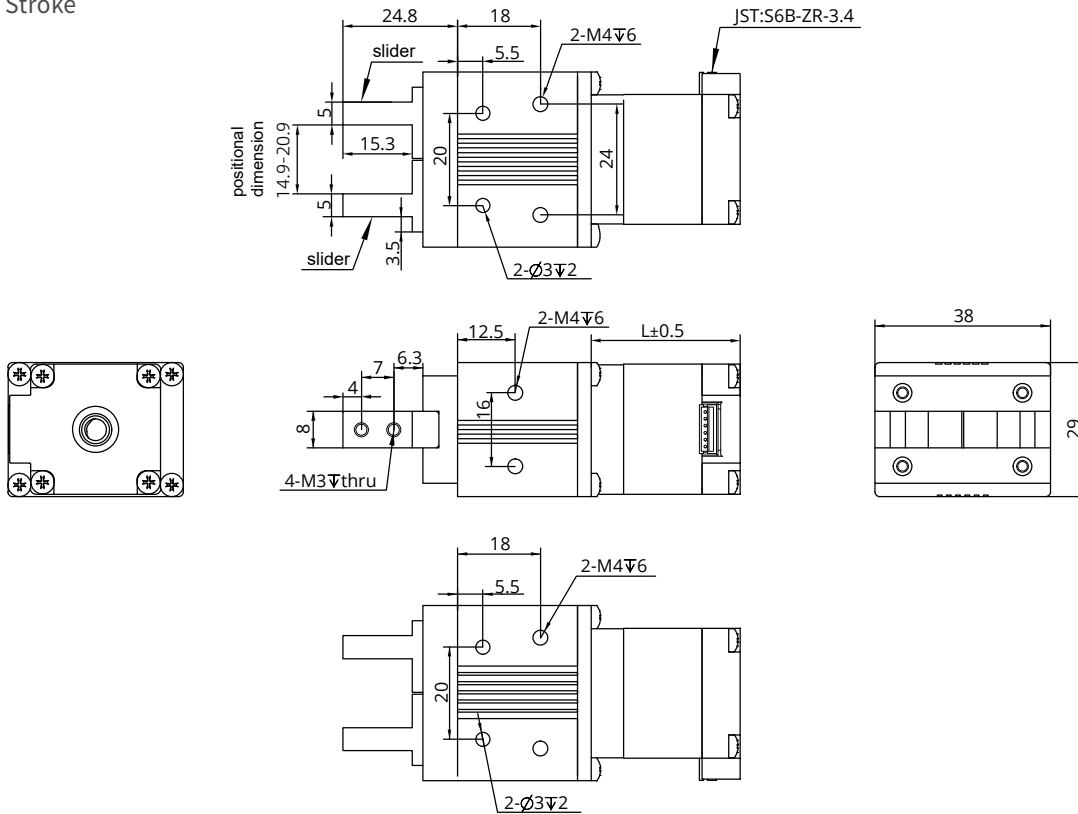

12mm Stroke

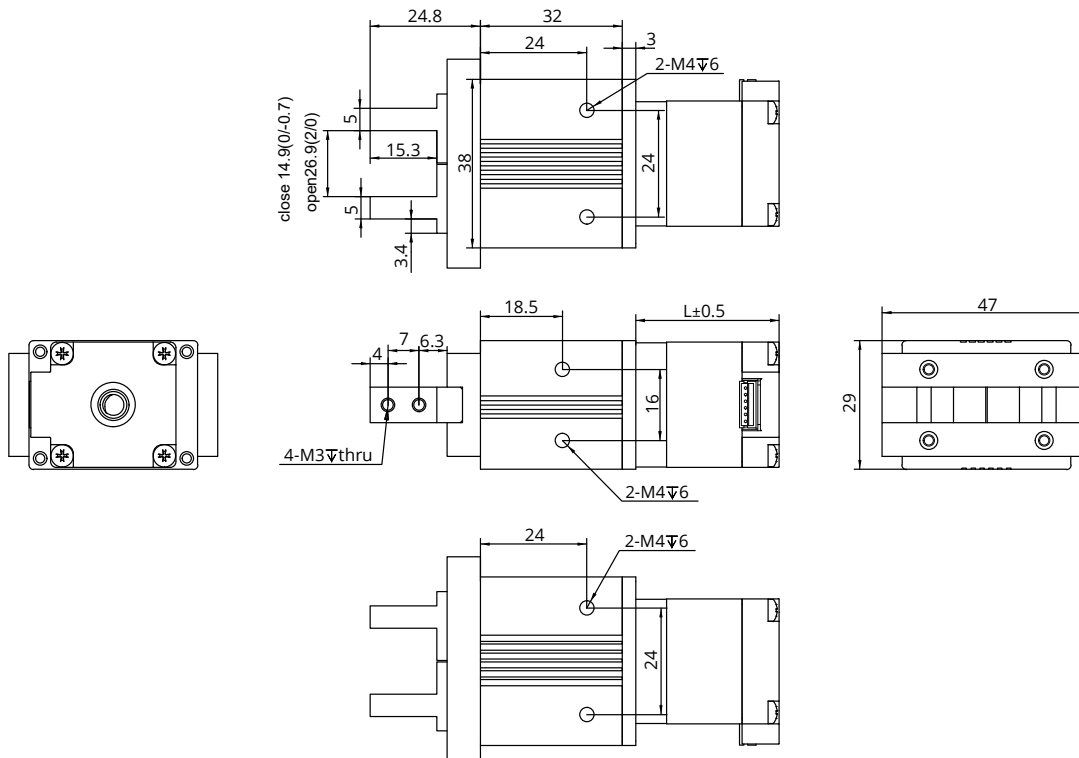

Note : All drawings are 1st Angle Projection - ISO Compliant (3D models available)

38mm 3-Finger Gripper

Motor Characteristics

Motor	Voltage (V)	Current (A _{RMS})	Resistance (Ω)	Inductance (mH)	Weight (g)	Lead wire No.	Motor length (mm)
14N2105	6.6	0.5	13.2	14	189	4	33.6
14N2110	3.5	1	3.5	3.6	189	4	33.6
14N2115	2.7	1.5	1.8	1.9	189	4	33.6
14N2205	12	0.5	24	29	210	4	45.6
14N2210	6	1	6	7.2	210	4	45.6
14N2215	4	1.5	2.7	3.2	210	4	45.6

Available Lead Screw and Travel per Step

Screw Dia. (inch)	Screw Dia. (mm)	Lead (inch)	Lead (mm)	Lead Code	Travel Per Step @1.8° (mm)*
0.25	6.35	0.024	0.6096	AA	0.003
0.25	6.35	0.05	1.27	D	0.0064
0.25	6.35	0.1	2.54	K	0.0127
0.25	6.35	0.2	5.08	R	0.0254

Dimensional Drawings

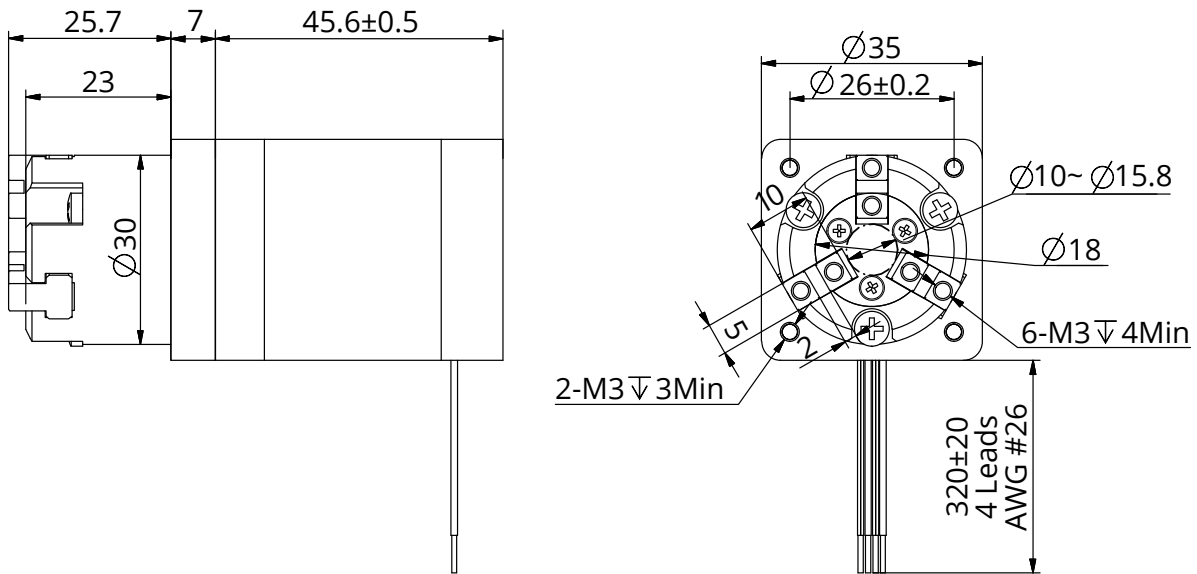

Note : All drawings are 1st Angle Projection - ISO Compliant (3D models available)

42mm 3-Finger Gripper

Motor Characteristics

Motor	Voltage (V)	Current (A _{RMS})	Resistance (Ω)	Inductance (mH)	Weight (g)	Lead wire No.	Motor length (mm)
17N2105	7.2	0.5	14.4	19.8	254	4	34.1
17N2110	3.8	1	3.8	5	254	4	34.1
17N2115	2.85	1.5	1.9	2.2	254	4	34.1
17N2205	11	0.5	22	46	386	4	48.1
17N2212	4.5	1.2	3.8	8	386	4	48.1
17N2225	2.5	2.5	1	1.8	386	4	48.1

Available Lead Screw and Travel per Step

Screw Dia. (inch)	Screw Dia. (mm)	Lead (inch)	Lead (mm)	Lead Code	Travel Per Step @1.8° (mm)*
0.25	6.35	0.024	0.6096	AA	0.003
0.25	6.35	0.05	1.27	D	0.0064
0.25	6.35	0.1	2.54	K	0.0127
0.25	6.35	0.2	5.08	R	0.0254

Dimensional Drawings

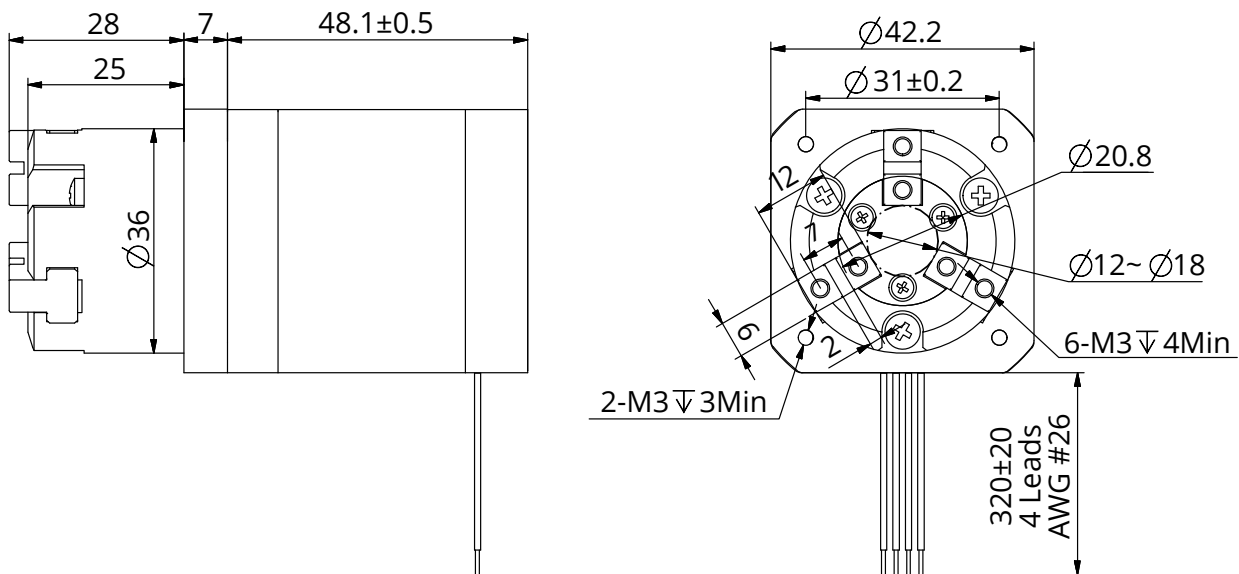

Note : All drawings are 1st Angle Projection - ISO Compliant (3D models available)

DINGS'

Precision Motion Specialist

Headquarter , CHINA

Jiangsu DINGS' Intelligent Control Technology Co., LTD

No.2850 Luheng Road, Changzhou Economic Development Zone, Jiangsu Province, China

Phone : +86-519-85177826

Fax : +86-519-85177807

E-mail : info@dingsmotion.com

www.dingsmotion.com

Shenzhen Office

Room 1105, Block C, CIMC industry demonstration park, Qiaoming Road, Guangming district, Shenzhen City

E-mail : info@dingsmotion.com

International Office

DINGS' Motion USA

355 Cochrane Circle Morgan Hill, CA 95037

Phone : +1-408-612-4970

E-mail : sales@dingsmotionusa.com

www.dingsmotionusa.com

DINGS' KOREA Co., Ltd

C-702, 158, Haneulmaeul-ro, Ilsandong-gu, Goyang-si, Gyeonggi-do, Republic of Korea

Phone : +82-31-994-0755

Fax : +82-70-4325-0755

E-mail : daniel@dingsmotion.com

www.dingsmotion.kr

DINGS' JAPAN

101, 2-27-18, Nishi-kojiya, Ota-ku, Tokyo 144-0034 JAPAN

Phone : +81-3-6811-1335

E-mail : tsukahara@dingsmotion.com

www.dingsmotion.com

- This catalog is the sole property of DINGS' and without the written authorization of DINGS', any copy or forwarding is prohibited.
- DINGS' reserves the right to make changes without further notification to any products herein to improve the reliability, function or design.
- DINGS' reserves the final interpretation.